

INSTRUCTION MANUAL

MODEL NTS2

2-jaw Parallel Gripper



DANGER

- This Instruction Manual has been prepared for intended use for production engineers and maintenance persons who operate this product. When the beginners use this product, be sure to receive the guidance from skilled persons, sales agents, or us in advance.
- Before installing, using, or maintaining this product, read carefully the safety precautions given in this manual so as to understand them completely. If you do not heed given instructions or safety precautions, serious human accidents, death, or physical damage may occur.
- Store this manual with care in the specified place at hand, and reread it as necessary for correct use of the product.
- Please contact the sales agent if you have any uncertainty or doubt about this manual.

Preface

This manual provides detailed information on the 2-jaw parallel gripper (model NTS2) so that you can understand its performance and functions and use it safely and correctly.

Before using this gripper, read this manual carefully to understand how to use the gripper correctly. Always follow the instructions and warnings given in **“Important Safety Precautions”** and **“Precautions for Use”**. Failure to follow these precautions could result in serious human accidents.

Terms and Symbols Used for Safety Messages

In this manual, handling precautions that are considered especially important are classified and displayed as shown below according to the degree of risk (seriousness of harm) that could result. Please completely understand the meaning of these terms and follow the instructions for safe operation.

Safety Alert Symbol

This triangle is a safety alert symbol used to alert you to potential safety hazards. To avoid death or injuries that could occur, follow the safety messages given with this safety alert symbol.



Failure to follow the safety precautions below will result in death or serious injuries.



Failure to follow the safety precautions below will result in death or serious injuries.



Failure to follow the safety precautions below may result in minor or moderate injuries.



Indicates instructions which, if you do not heed given instructions, could result in damage to the product or shortened service life, or damage to peripheral equipment.

Disclaimer and How to Use Instruction Manual

This product is suitable for gripping a conveyed workpiece by being installed on the robot or loader. The product is equipped with the jaws to grip the conveyed workpiece and they are operated by air pressure. For any other applications, please contact us.

Kitagawa Iron Works Co., Ltd. shall not be held liable for human accidents, death, damage, or loss that occurred due to a failure to follow the safety precautions given in this manual.

This manual does not predict all potential hazards in operation, inspection, and maintenance under all environmental conditions. There will be an infinite number of matters that cannot or must not be done, and it is impossible for the manual to cover all of them.

Therefore, the matters, unless otherwise mentioned clearly as “can be done” or “may be done” in this manual, should be considered as “cannot be done” or “must not be done”.

Please contact us or our agents if you have an uncertainty about safety when you try to perform operation, inspection, or maintenance not mentioned in this manual.

Warranty and Disclaimer

The product is warranted for one year after the date of delivery.

All parts used shall be those delivered by Kitagawa Corporation. Kitagawa Corporation shall not be held liable for human accidents, death, damage, or loss that occurred due to the use of parts which are not genuine parts manufactured by Kitagawa. Also, the use of parts other than Kitagawa’s genuine parts will void the warranty.

Contents

1. Structural Drawing and Parts List	4
1-1. Model indication	
1-2. Structural drawing	
1-3. Seal list	
1-4. Parts list	
2. Important Safety Precautions	8
3. Specifications	12
3-1. Specification table	
3-2. Gripping force	
4. Use	16
5. Design of Jaws	17
5-1. Designing jaws to be installed on the gripper	
6. Installation	19
6-1. Installing the gripper	
6-2. Installing the jaws	
6-3. Connecting the air piping	
6-4. Installing the switches	
7. Maintenance and Checking	30
7-1. Periodic checking	
7-2. Maintenance interval	
7-3. Grease	
7-4. Air circuit maintenance	
7-5. Disassembly and assembly procedure	
8. Troubleshooting	34
8-1. Gripper is faulty	
8-2. Contact address in case of trouble	
9. Others	36
9-1. Standards and directives to which the gripper conforms	
9-2. Disposal of gripper	

1. Structural Drawing and Parts List

1-1. Model indication

The model indication is as follows:

NTS2 08 H - M

Series		Size			Gripping force		Master jaw	
NTS2	NBR seal	06	08	10	Nil	Standard	Nil	Standard
		12	16	20	H	High gripping force	M	Bush type master jaw
		30						

※There are two types of NTS230, NTS230-M and NTS230H-M.

1-2. Structural drawing

① NTS206

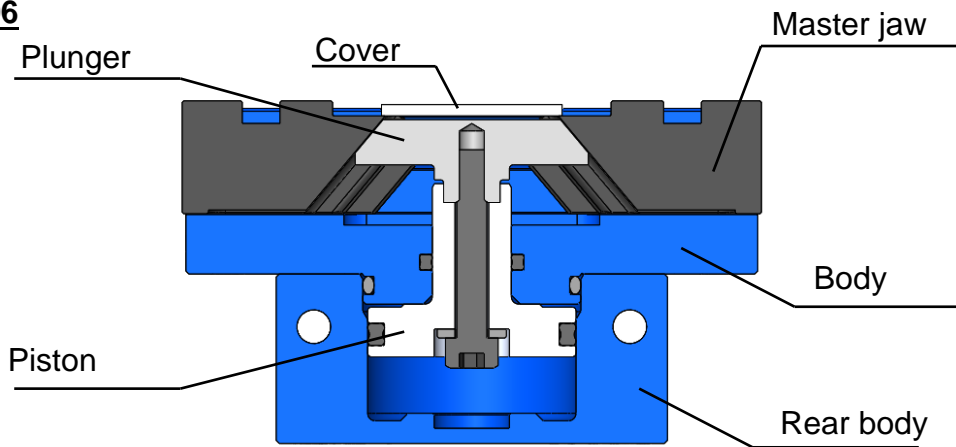

② NTS208, NTS210, NTS212, NTS216

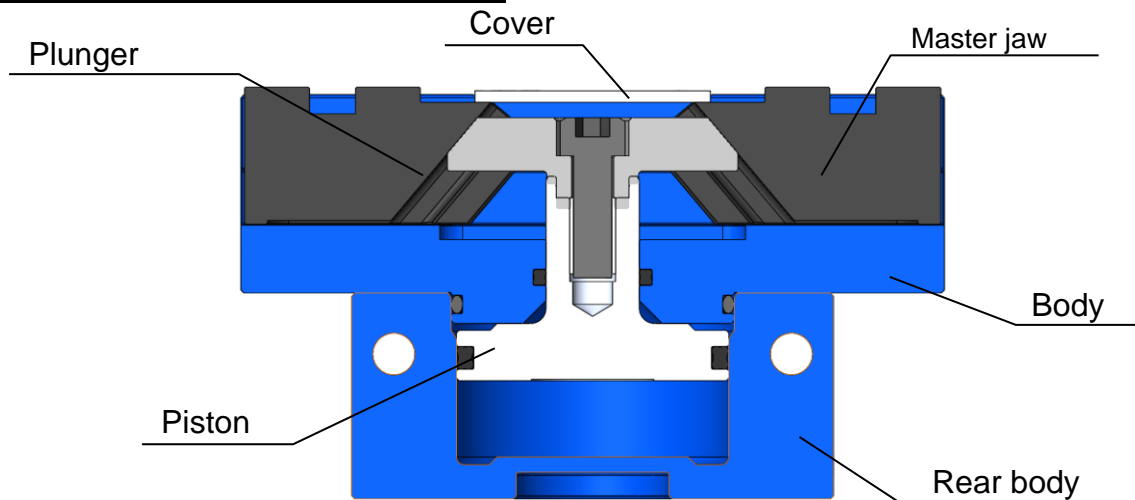

1-3. Seal list

Model	No.				
	202	203	204	205	209
NTS206	X-ring X013	X-ring X118	O-ring S25	O-ring P3	Seal washer 4S1

Model	No.			
	202	203	204	205
NTS208	X-ring X014	X-ring X123	O-ring S30	O-ring P4
NTS210	X-ring X114	X-ring X128	O-ring S40	O-ring P4
NTS212	X-ring X116	X-ring X133	O-ring S48	O-ring P6
NTS216	X-ring X119	X-ring X142	O-ring S60	O-ring P6
NTS220	X-ring X122	X-ring X234	O-ring S80	O-ring P6
NTS230-M	X-ring X122	X-ring X243	O-ring S110	-
NTS230H-M	X-ring X122	X-ring X243	O-ring S110	-

1-4. Seal list

① NTS206

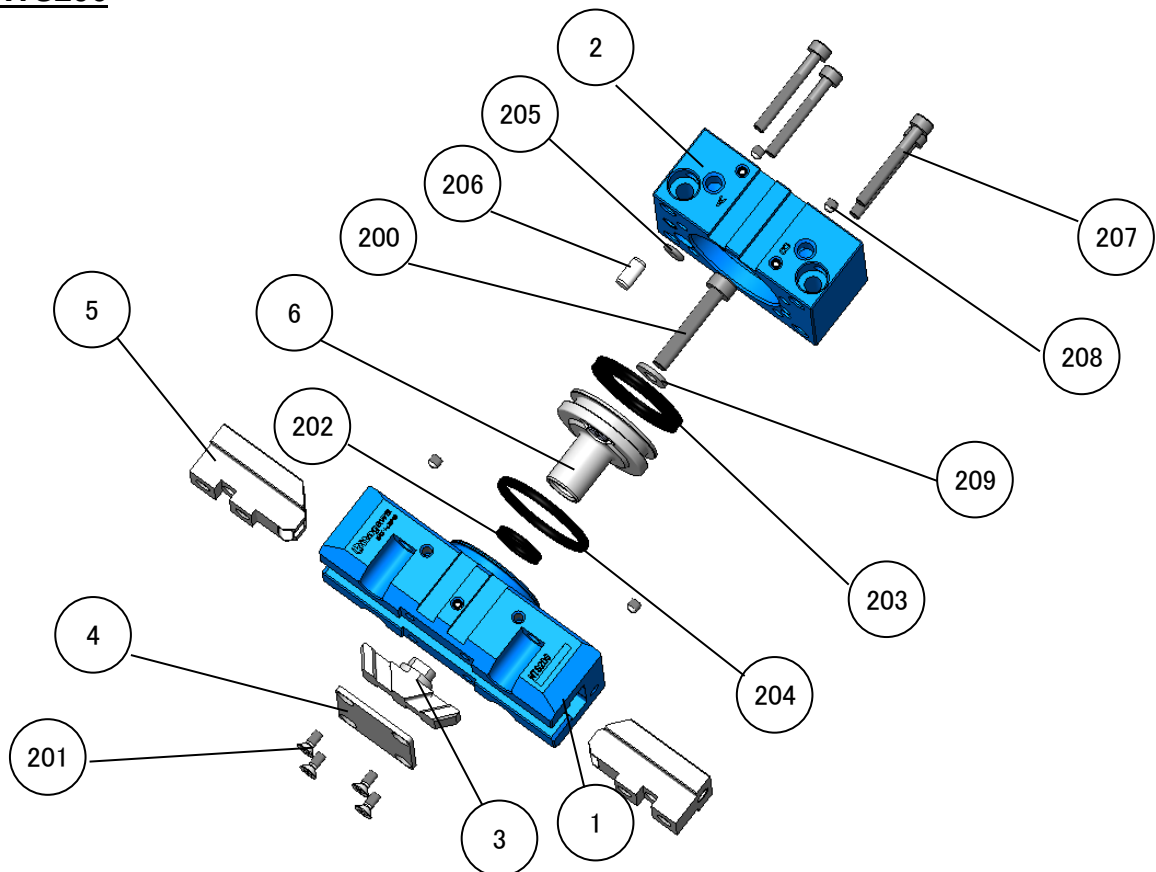

② NTS208, NTS210, NTS212, NTS216

③

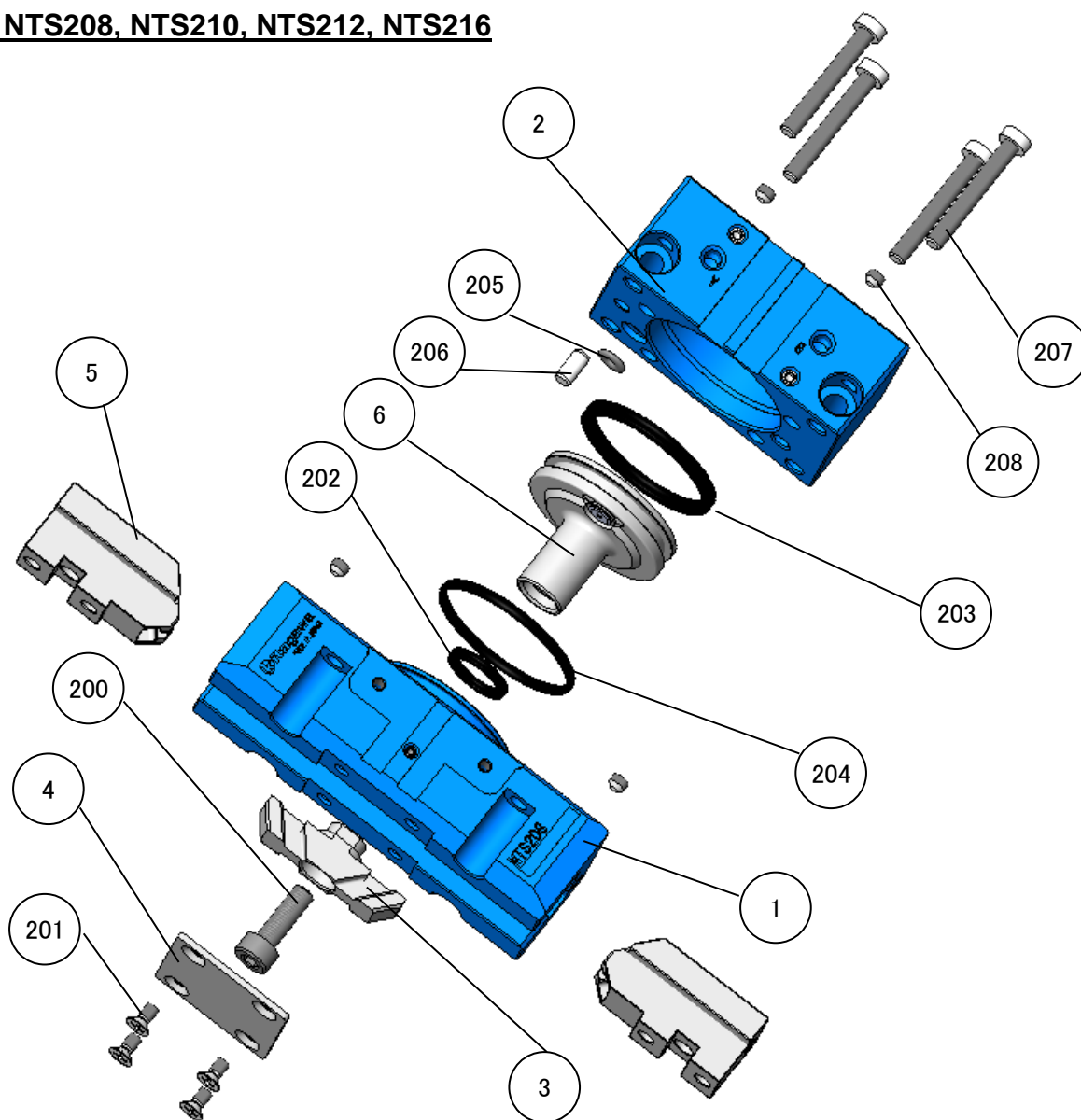

No.	Parts name	Quantity	No.	Parts name	Quantity
1	Body	1	202	Shaft packing	1
2	Rear body	1	203	Piston packing	1
3	Plunger	1	204	O-ring A	1
4	Cover	1	205	O-ring B	1
5	Master jaw	2	206	Parallel pin	1
6	Piston	1	207	Rear body fixing bolt	4
200	Piston fixing bolt	1	208	Setscrew	4
201	Cover fixing bolt	4	209	Seal washer	1

※There are 6 No.207 rear body fixing bolts for NTS216 and 8 for NTS220.

※No.209 Seal washer is a part only for NTS206.

④ NTS230

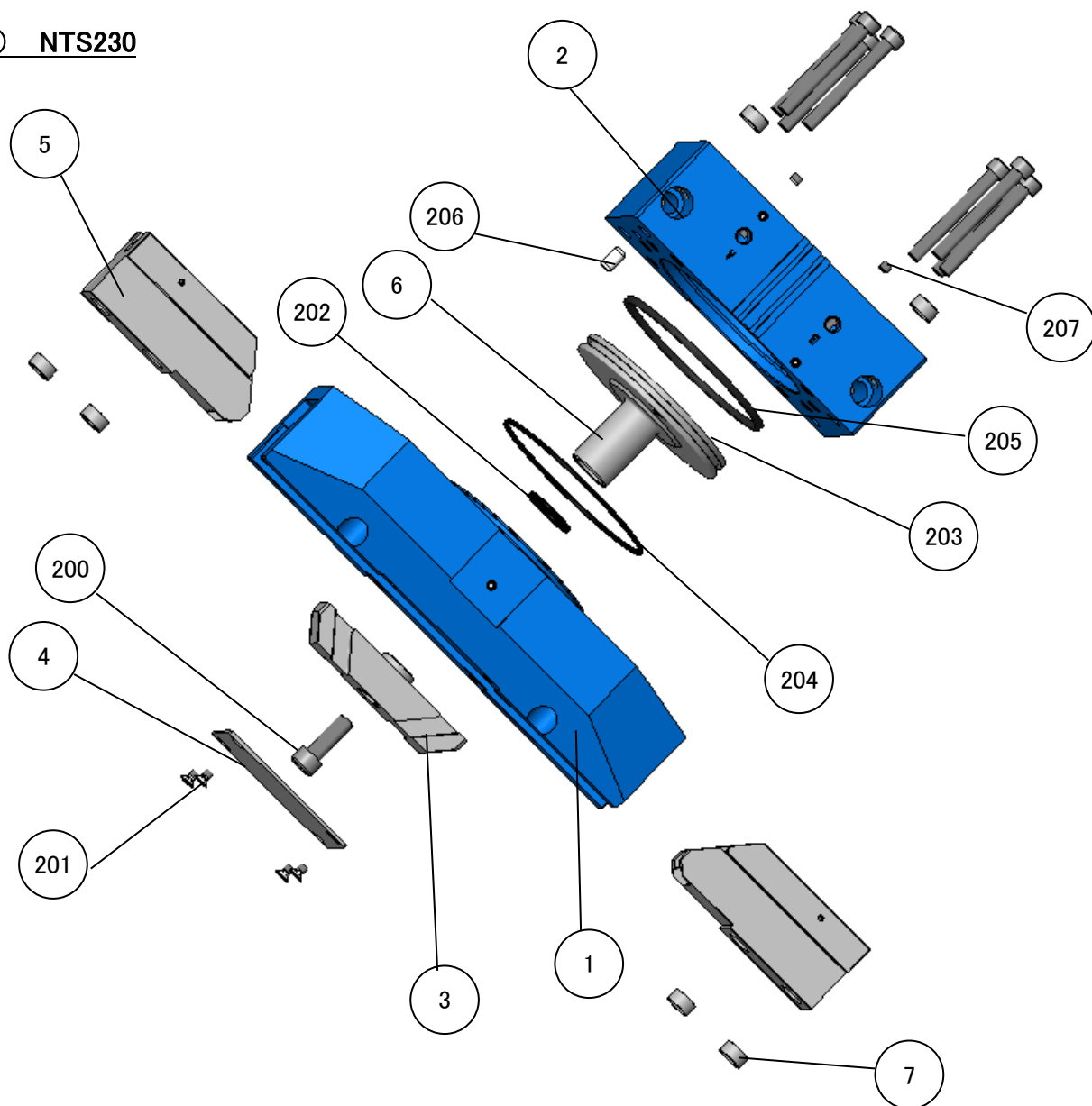

No.	部品名称	個数	No.	部品名称	個数
1	Body	1	200	Piston fixing bolt	1
2	Rear body	1	201	Cover fixing bolt	4
3	Plunger	1	202	Shaft packing	1
4	Cover	1	203	Piston packing	1
5	Master jaw	2	204	O-ring	1
6	Piston	1	205	Setscrew	2
7	Bush	6	206	Parallel pin	1
			207	Rear body fixing bolt	8

2. Important Safety Precautions

Important safety precautions that particularly you should know or follow are summarized below. Please read them before starting to use the product.



DANGER

Failure to follow the safety precautions below will result in death or serious injuries.



Be sure to turn off the main power supply when installing, checking, oiling, or replacing the gripper.

Also, shut down the air pressure in the work area.

- During work, the robot or gripper could move abruptly and collide with your body.
- After shutting down the air pressure, release the air pressure remaining inside the gripper.

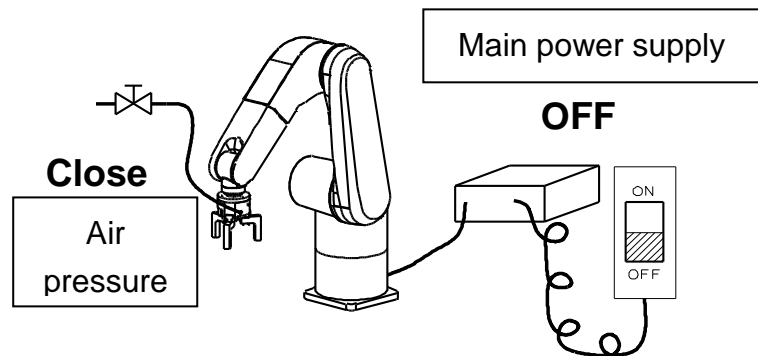

When installing, checking, oiling, or replacing the gripper, post a sign or notice, or provide a fence, and so on to notify people around the machine that work is in progress.

- Notify people around the machine that work is in progress and take measures to keep people other than the operator out of the work area.
Machine motion not predicted by a third party could cause serious danger.



Take safety measures so that the operator is not injured even if the conveyed workpiece flies out due to the reduced air pressure.

- Observe the legal safety standards defined by each country, such as installation of safeguards or fall prevention covers.

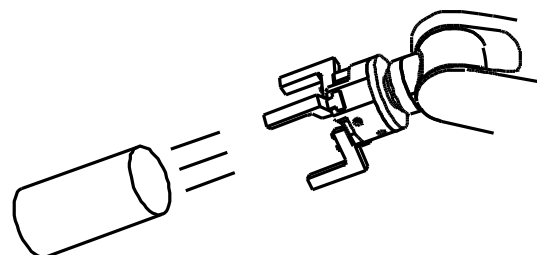



DANGER

Failure to follow the safety precautions below will result in death or serious injuries.



Do not modify the gripper.

- Not only the gripper is damaged but also the gripper and fixed workpiece may fly out.

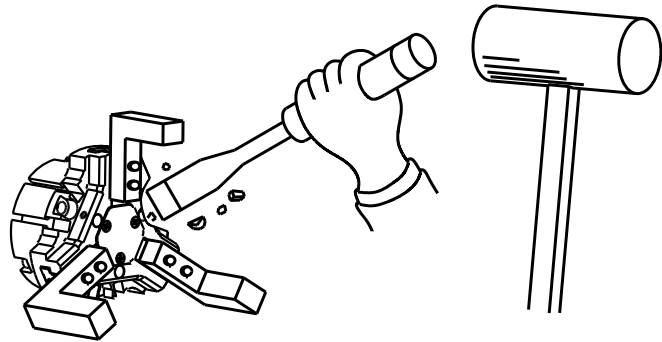

If using the gripper as a workpiece fixture when the workpiece is drilled, deburred, welded, or modified additionally, confirm the specifications.

- If the gripper is used out of the specifications, not only the gripper is damaged but also the fixed workpiece may fly out.



Be sure to tighten the bolts with the specified torque.

- Lack of bolt quantity or tightening torque, or excessive torque could damage the bolt, causing the gripper or conveyed workpiece to fly out.
- When tightening the bolts, fix the gripper so that it will not rotate. Failure to do so may result in injury by slipping your hands when tightening the bolts.

Other than piston fixing bolt			Piston fixing bolt		
Bolt Size	Tightening torque		Bolt Size	Tightening torque	
M3	1.0	N·m	M5	6.8	N·m
M4	2.0	N·m	M6	12.7	N·m
M5	4.5	N·m	M8	33.3	N·m
M6	7.65	N·m	M10	72.6	N·m
M8	18.0	N·m			



DANGER

Failure to follow the safety precautions below will result in death or serious injuries.



Use the gripper in accordance with the legal safety standards.

- Use the gripper in accordance with the legal safety standards defined by each country, such as installation of safeguards or safety covers.

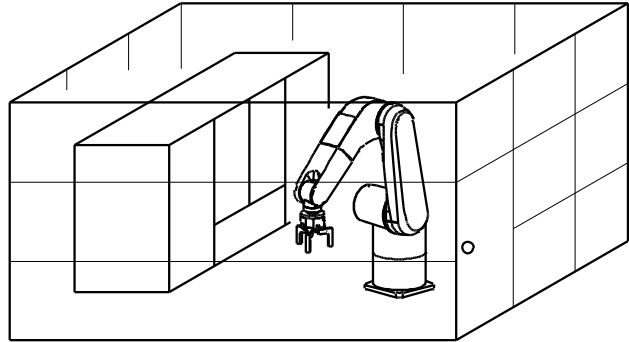



WARNING

Failure to follow the safety precautions below will result in death or serious injuries.



Do not operate the machine after drinking alcohol or taking medicine.

- Impaired judgment or operation mistake may cause serious hazards.

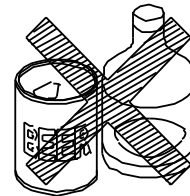

Alcohol

Medicine



Do not wear clothing or accessories such as a necktie, necklace, etc. which are easy to be caught in.

- You may be caught in the gripper.

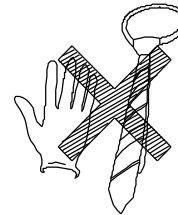

Use the gripper within the range of specification values.

- When selecting a gripper, select the model by referring to "Model selection" in page 11.
- Have the gripper grip the conveyed workpiece at the position of its center of gravity.
- If not, not only the gripper is damaged but also the conveyed workpiece may fly out.

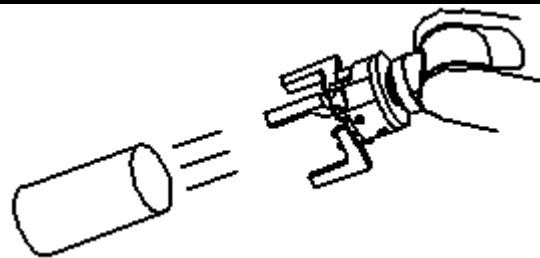

3. Specifications

3-1. Specification table

Model	NTS							
	Standard gripping force							High gripping force
	206	208	210	212	216	220	230-M	230H-M
Fluid used	Air pressure							Air pressure
Operating air pressure (MPa)	0.2 - 0.8							0.2-0.6
Ambient temperature range (°C)	5 - 60							5 - 60
Jaw stroke in diameter (mm)	12	16	20	24	32	40	60	41
Cylinder internal volume (reciprocation) (cm ³)	8.4	18.8	35.1	52.4	123.2	272.2	683.4	683.4
Repeatability (mm)	±0.01						±0.02	±0.02
Body mass (kg)	0.29	0.47	0.77	1.33	2.51	5.14	10.4	10.4
Ambient humidity range (%)	30 - 95							30 - 95
Storage temperature range (°C)	-10 - 60							-10 - 60
Noise level (dB)	79							79

*Noise level is measured at a distance of 1m from the gripper in front, rear, left, and right four positions of the gripper.

NOTICE

- Models with high gripping force use different air pressure than models with standard gripping force. If used outside the specifications, the internal parts of the gripper may be damaged.

3-2. Gripping force

① Standard for selecting a model

Perform the following calculation and select the model that provides a gripping force exceeding the calculation result, though a gripping force varies depending on the shapes of jaws created by the customer and conveyed workpiece or the friction coefficient.

$$F = m(g+a)/\mu$$

(Example)

When mass of conveyed workpiece = 8 kg, friction coefficient = 0.1, and robot acceleration = 10m/s²:
 $F = 8(9.8+10)/0.1 = 1584 \text{ (N)}$

F = Gripping force (N)

m = Mass of conveyed workpiece (kg)

g = Gravitational acceleration (m/s²)

a = Acceleration of robot/loader (m/s²)

μ = Friction coefficient of gripping part

② Gripping force

● External gripping

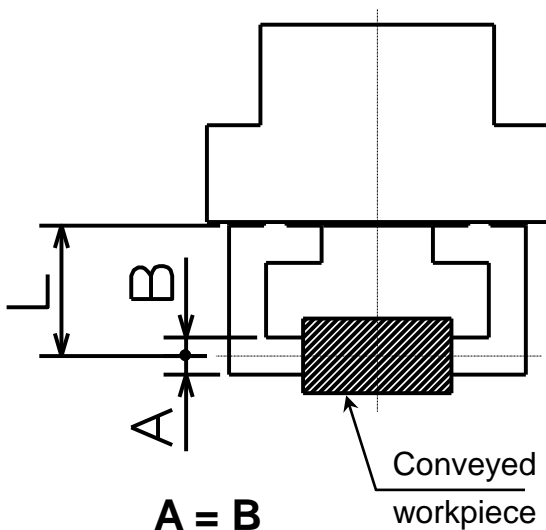

● Internal gripping

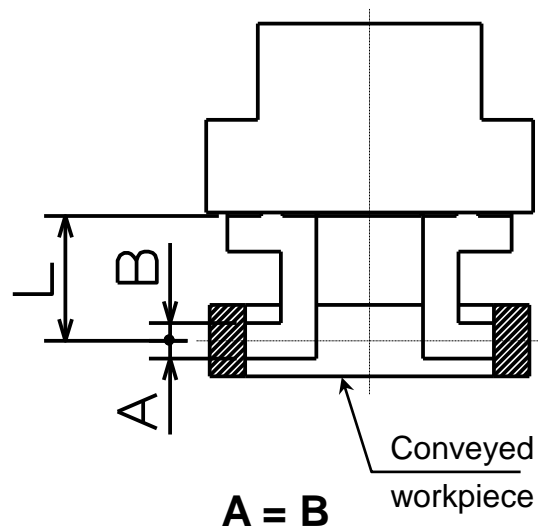

L: Distance up to a grip point (mm)

● Expression of gripping force

A gripping force F shown in graph is actually measured gripping force per jaw F1 x the number of jaws.

$$(F = F1 \times 2)$$



—— External gripping

----- Internal gripping

NOTICE

- Determine the distance up to a grip point L as short as possible when designing the jaws. Also, the distance up to a grip point L should be used within a range shown in graph. If it is used out of the range, not only the specified gripping force may not be obtained but also the wear of sliding parts may be increased.

■ **NTS206**

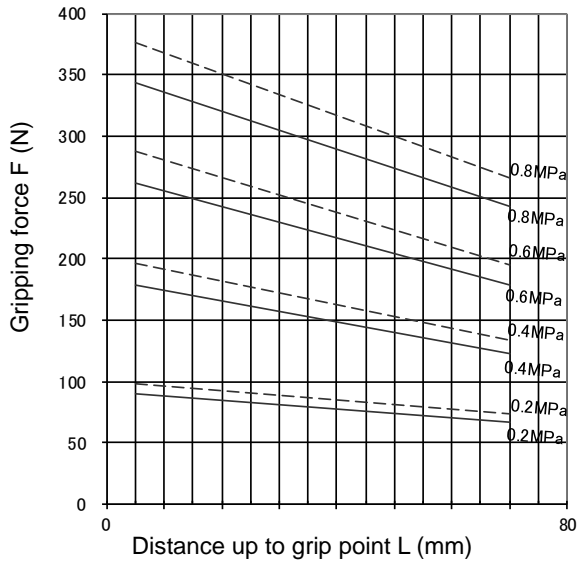

■ **NTS208**

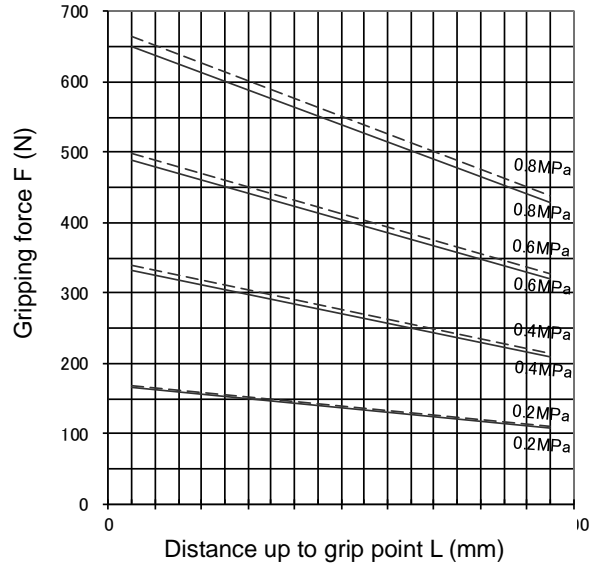

■ **NTS210**

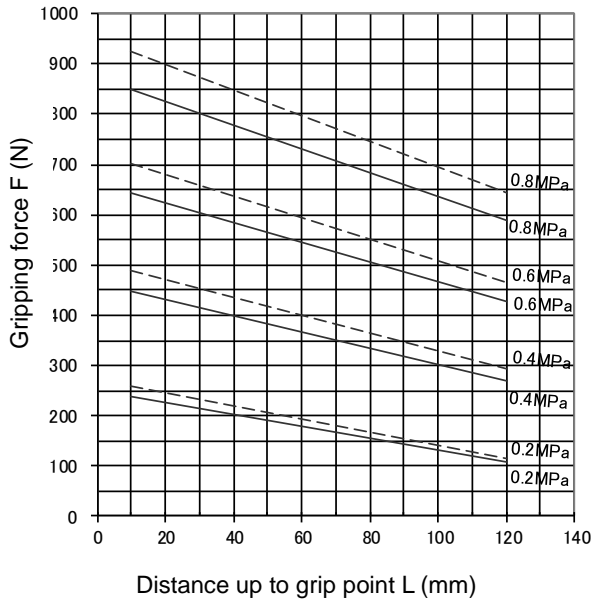

■ **NTS212**

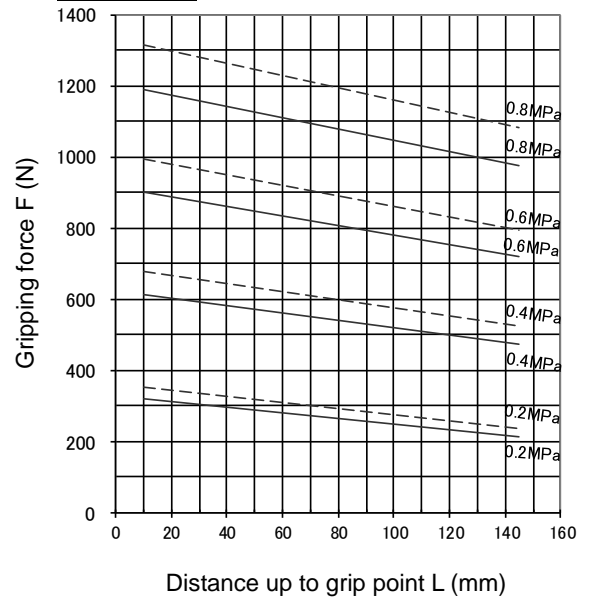

■ NTS216

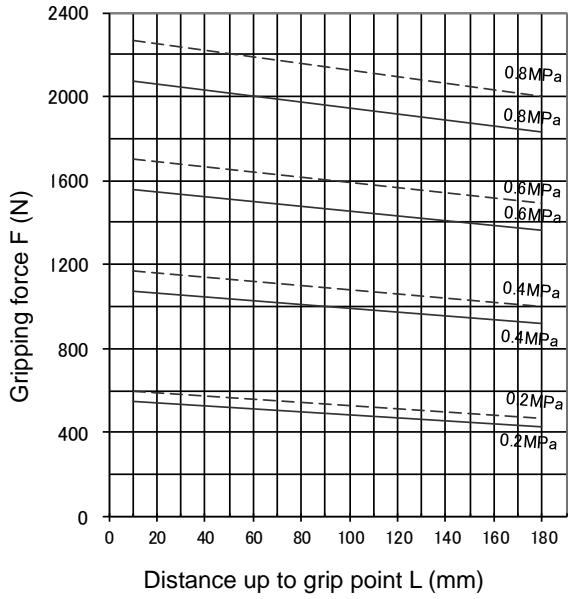

■ NTS220

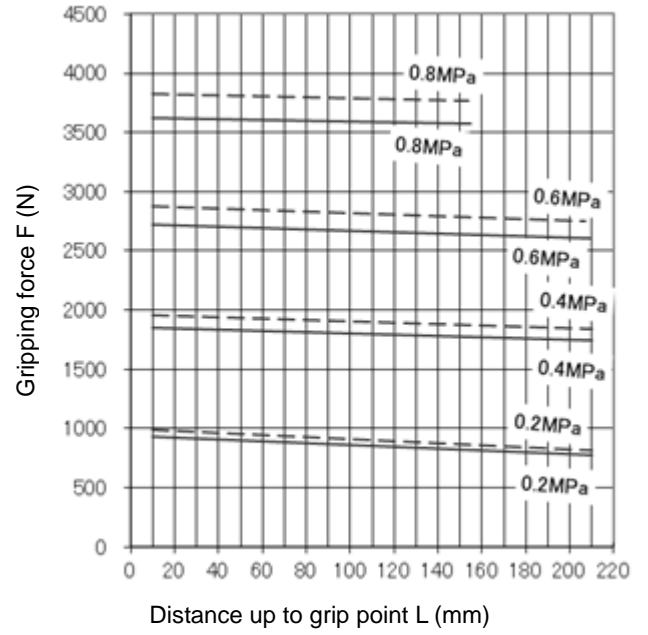

■ NTS230-M

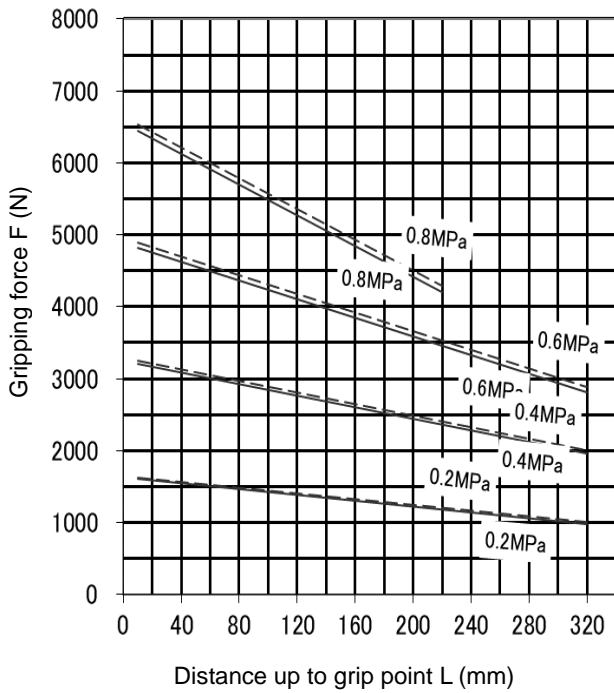

■ NTS230H-M

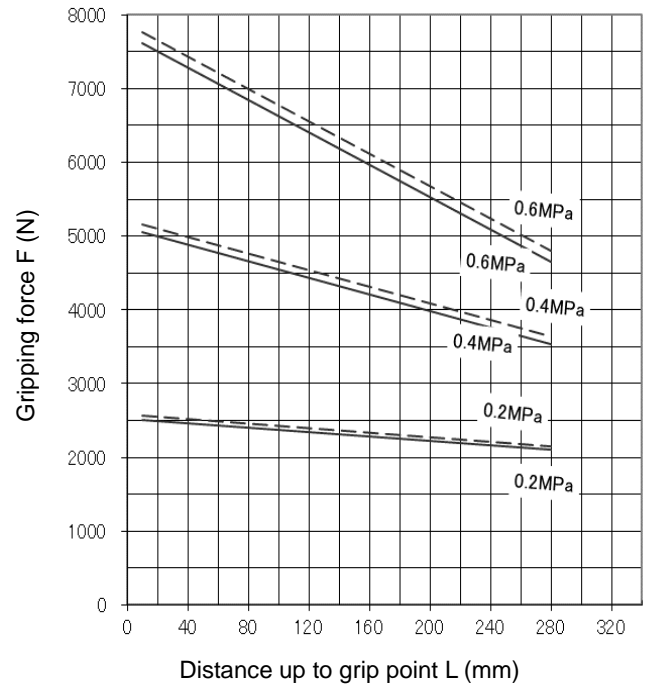

4.Use

This product supplies pneumatic pressure to the unit to move the jaws in the open or close direction for gripping the conveyed workpiece and transfers the conveyed workpiece up to any location. After transfer, the jaws are moved in the close or open direction for removing the conveyed workpiece.

DANGER

- Do not modify the gripper. Using the modified product could cause unexpected accidents. Kitagawa shall not be held liable for human accidents, death, damage, or loss that occurred due to the modification.

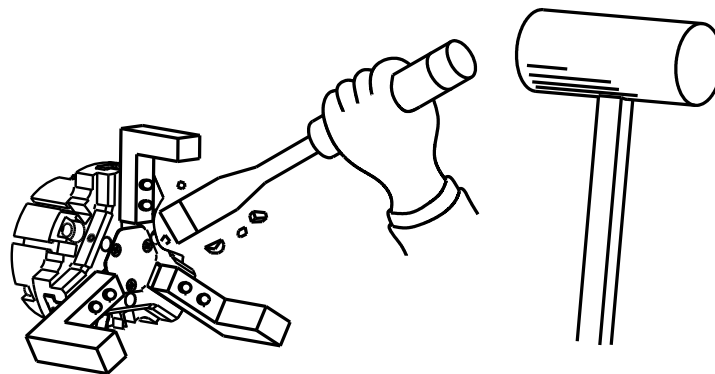

- If using the gripper as a workpiece fixture when the workpiece is drilled, deburred, welded, or modified additionally, confirm the specifications. If the gripper is used out of the specifications, not only the gripper is damaged but also the fixed workpiece may fly out.

WARNING

- Wear appropriate clothing suitable for the work and wear gloves, safety glasses, safety shoes, and helmet.
 - Wearing inappropriate clothing causes the clothing to be stuck, resulting in danger.
 - Appropriate clothing will be preventive measures to prevent hazards due to the carelessness or unexpected accidents during work.

NOTICE

- Do not use the product in the environment of corrosive chemicals, corrosive gas, dust, and vibration, avoiding high temperature or direct sunlight.
- When storing the product, apply antirust treatment and then store it in a place free from water leakage, dew condensation, or freeze.

5. Design of Jaws

5-1. Designing jaws to be installed on the gripper(standard)

When designing jaws to be installed on the gripper, form the installation face to the master jaw as shown below.

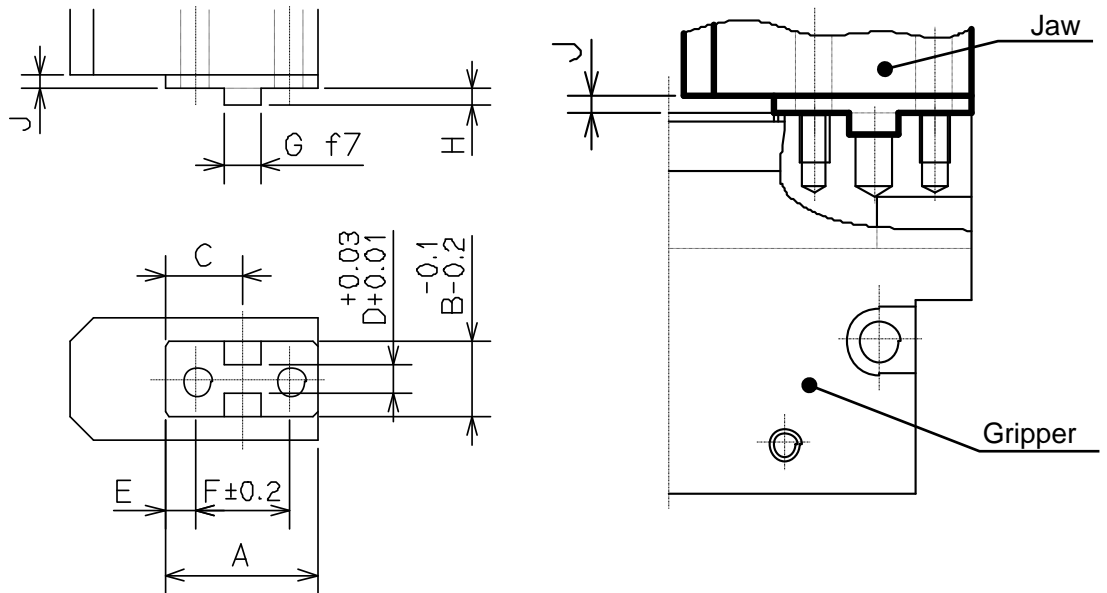

Model	A	B	C	D ^(*)	E	F	G ^(*)	H ^(*)	J
NTS 206	20	11	9.5	4	3	13	5	2.5	0.5
NTS 208	23	13.5	11.5	5	3.5	16	6	3	0.5
NTS 210	28.5	18.5	14	6	4	20	8	3.5	0.5
NTS 212	35	19	18	6	6	24	8	4	0.5
NTS 216	46	28.5	23	8	7	32	10	4	0.5
NTS 220	59.5	36	29	10	9	40	12	4.5	0.5

* Dimensions D, G, and H in the table are used for positioning the jaws. Dimension D is used for positioning in the lateral direction, and dimensions G and H are used for positioning in the longitudinal direction.

5-2. Designing jaws to be installed on the gripper(NTS2**-M)

When designing jaws to be installed on the gripper, form the installation face to the master jaw as shown below.

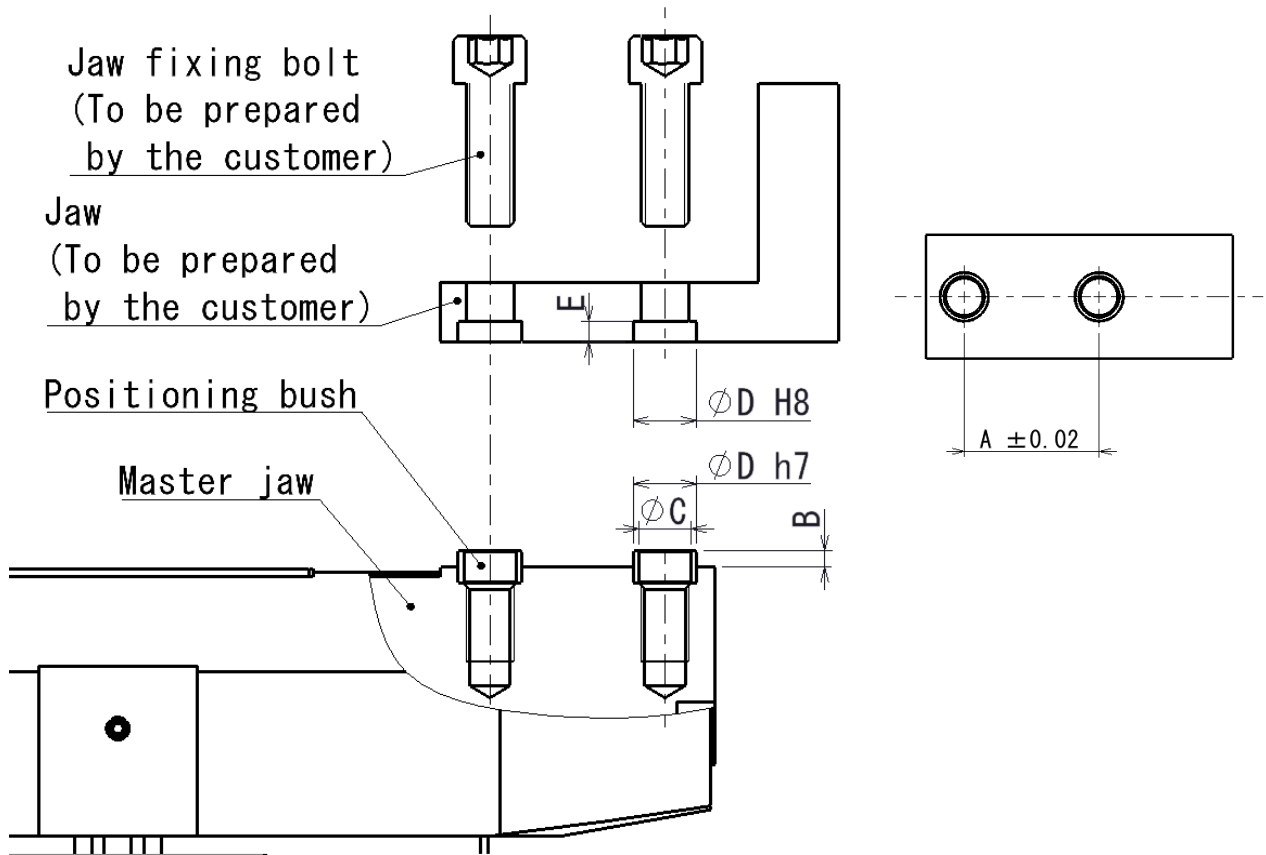

Model	A	B	C	D	E
NTS 230(H)-M	44	4	13	16	5

6. Installation

6-1-1. Installing the gripper(standard)

① Front face installation

Install the gripper body using the four fixing bolt holes and the two positioning pin holes or the center fitting portion.

The gripper fixing adapter, gripper fixing bolts, and positioning pins are to be prepared by the customer.

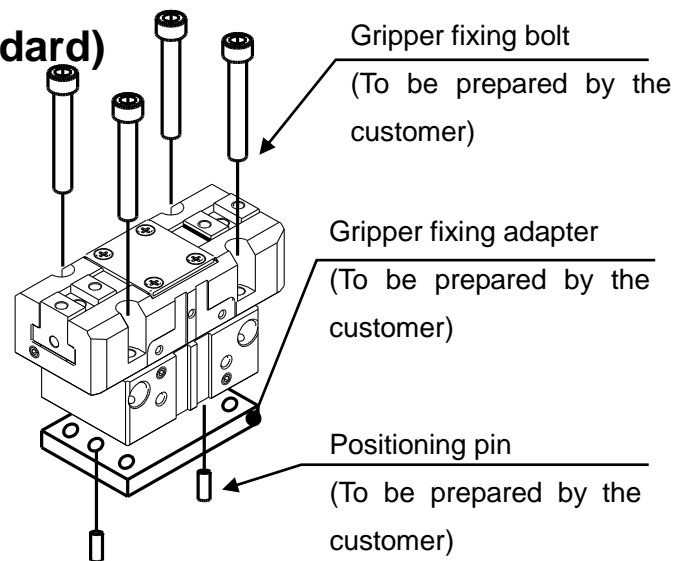

Model	NTS	206	208	210	212	216	220
Gripper fixing bolt size		M4	M4	M5	M6	M6	M8
Positioning pin hole	Diameter ($0^{+0.025}$) (mm)	$\phi 4$	$\phi 4$	$\phi 5$	$\phi 6$	$\phi 6$	$\phi 10$
	Depth (mm)	5.5	6	8	10	10	15
Fitting portion size (depth)		-	$\phi 20H8$ (3.5)			$\phi 40H8$ (3.5)	

② Rear face installation

Install the gripper body using the four fixing bolt holes and two positioning pin holes or the center fitting portion.

The gripper fixing adapter, gripper fixing bolts, and positioning pin are to be prepared by the customer.

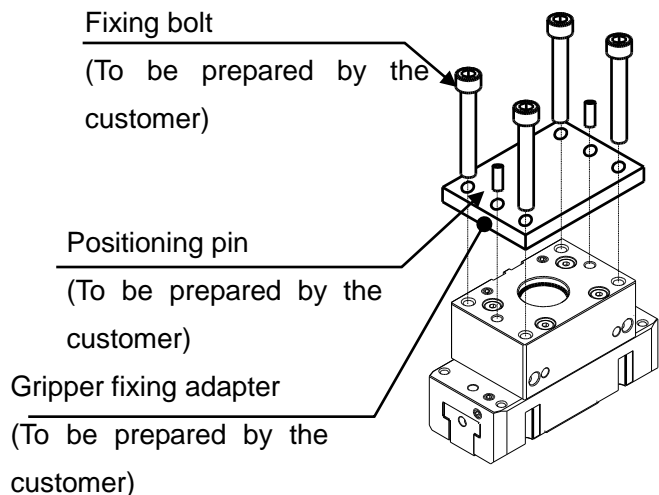

Model	NTS	206	208	210	212	216	220
Gripper fixing bolt	Size	M5	M5	M6	M8	M8	M10
	Thread depth (mm)	8	10	12	16	16	15
Positioning pin hole	Diameter ($0^{+0.025}$) (mm)	$\phi 4$	$\phi 4$	$\phi 5$	$\phi 6$	$\phi 6$	$\phi 10$
	Depth (mm)	5.5	6	8	10	10	15
Fitting portion size (depth)		-	$\phi 20H8$ (3.5)			$\phi 40H8$ (3.5)	

③ Side face installation

Install the gripper body using the two fixing bolt holes and two positioning pin holes.

The gripper fixing adapter, gripper fixing bolts, and positioning pin are to be prepared by the customer.

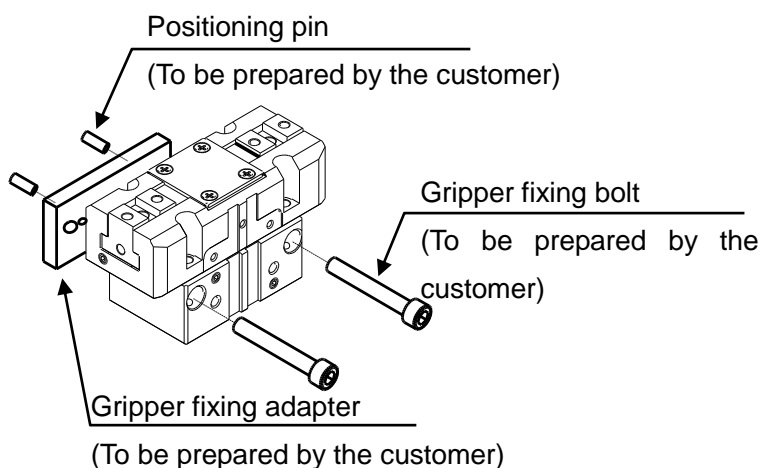

Model	NTS	206	208	210	212	216	220
Gripper fixing bolt size		M4	M5	M6	M8	M8	M10
Positioning pin hole	Diameter ($0^{+0.025}$) (mm)	$\phi 4$	$\phi 4$	$\phi 5$	$\phi 6$	$\phi 6$	$\phi 10$
	Depth (mm)	5	6	8	10	10	15

④ Intermediate face installation

Install the gripper body using the four fixing bolt holes and two positioning pin holes.

The gripper fixing adapter, gripper fixing bolts, and positioning pin are to be prepared by the customer.

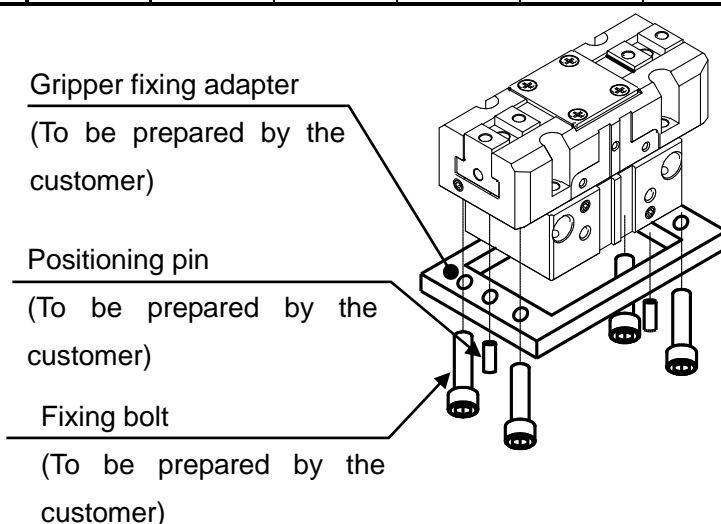

Model	NTS	206	208	210	212	216	220
Gripper fixing bolt size		M3	M4	M4	M5	M5	M6
Positioning pin hole	Diameter ($0^{+0.025}$) (mm)	$\phi 4$	$\phi 4$	$\phi 5$	$\phi 5$	$\phi 6$	$\phi 8$
	Depth (mm)	5.5	6	5	7	7	8



- Be sure to tighten the bolts with the specified torque. Lack of tightening torque or excessive torque could break the bolts, causing the gripper or conveyed workpiece to fly out.

6-1-2. Installing the gripper(NTS2**-M)

① Front face installation

Install the gripper body using the four fixing bolt holes and the two positioning bush.

The gripper fixing adapter and gripper fixing bolts are to be prepared by the customer.

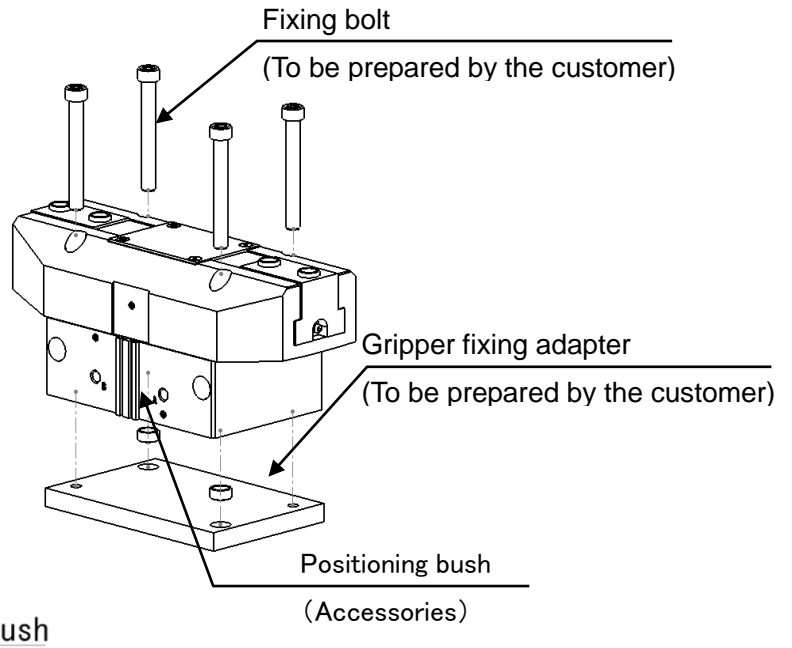
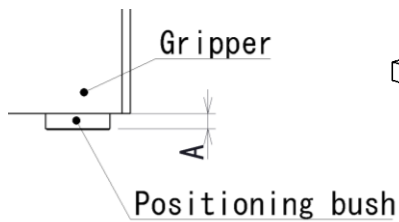

Model		NTS	230(H)-M
Gripper fixing bolt size			M10
Positioning bush	Diameter (h7)	(mm)	φ16
	Jutting amount	A (mm)	4

② Rear face installation

Install the gripper body using the four fixing bolt holes and two positioning bush.

The gripper fixing adapter and gripper fixing bolts are to be prepared by the customer.

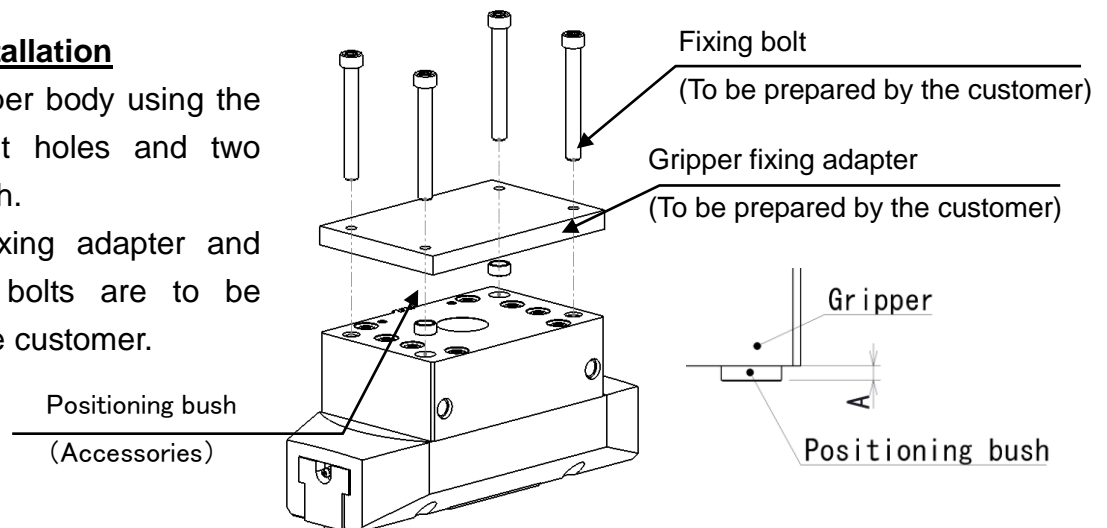

型式		NTS	230(H)-M
Gripper fixing bolt	Size		M12
	Thread depth	(mm)	25
Positioning bush	Diameter (h7)	(mm)	φ16
	Jutting amount	A (mm)	4

③ Side face installation

Install the gripper body using the two fixing bolt holes and two positioning bush.

The gripper fixing adapter and gripper fixing bolts are to be prepared by the customer.

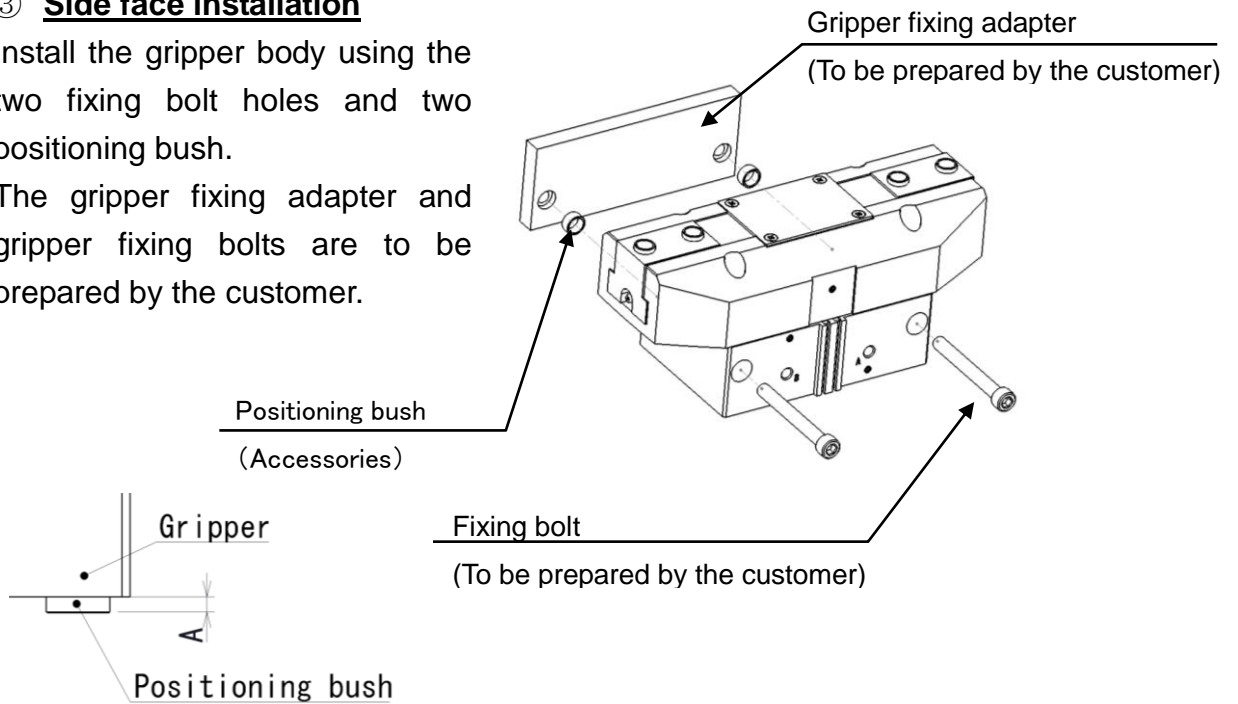

Model	NTS		230(H)-M
Gripper fixing bolt size			M12
Positioning bush	Diameter (h7)	(mm)	$\phi 16$
	Jutting amount	A (mm)	4

! DANGER

- Be sure to tighten the bolts with the specified torque. Lack of tightening torque or excessive torque could break the bolts, causing the gripper or conveyed workpiece to fly out.

NOTICE

- NTS230(H)-M does not support intermediate surface mounting.

6-2-1.Installing the jaws(standard)

Install the jaws using two mounting bolt holes, fitting portion, and positioning pin hole.

The jaws, jaw fixing bolts, and positioning pins are to be prepared by the customer.

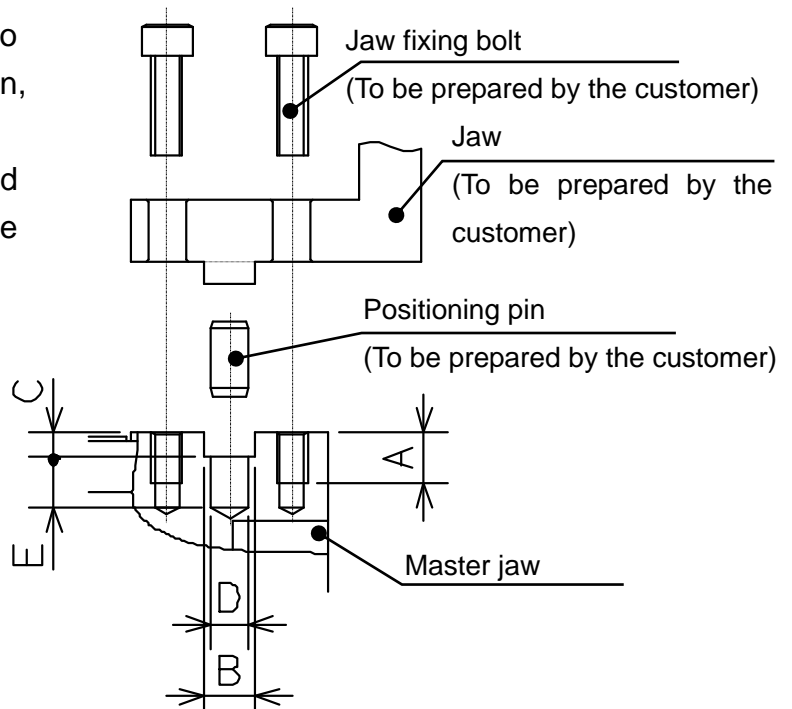
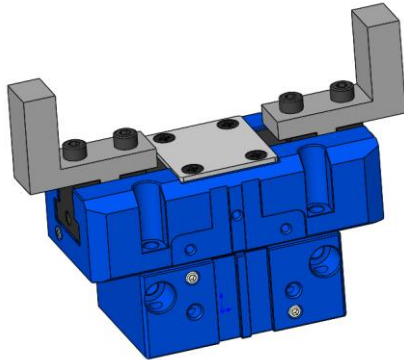

Model		NTS	206	208	210	212	216	220
Mounting bolt	Size		M4	M4	M5	M6	M8	M10
	Thread depth A(mm)		6	7	8	9	12	15
Fitting portion	Width (H8) B (mm)		5	6	8	8	10	12
	Depth C (mm)		3	3.5	4	4.5	4.5	4.5
Positioning pin hole	Diameter (H8) D (mm)		φ4	φ5	φ6	φ6	φ8	φ10
	Depth E (mm)		5	6	8	8	12	15

DANGER

- Be sure to tighten the bolts with the specified torque. Lack of tightening torque or excessive torque could break the bolts, causing the jaws or conveyed workpiece to fly out.
- Before installing the jaws, disconnect the air piping.

6-2-2.Installing the jaws(NTS2**-M)

Install the jaws using two mounting bolt holes, and positioning bush.

The jaws, and jaw fixing bolts are to be prepared by the customer.

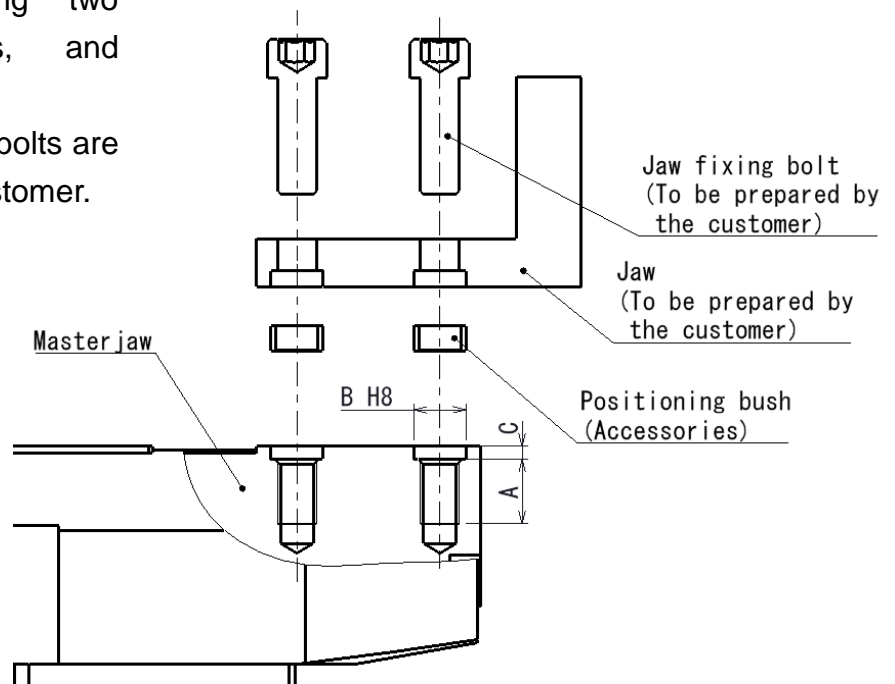

Model		NTS	230(H)-M
Mounting bolt	Size		M12
	Thread depth	A(mm)	20
Positioning bush	Diameter (h7)	B(mm)	16
	Depth	C(mm)	4



- Be sure to tighten the bolts with the specified torque. Lack of tightening torque or excessive torque could break the bolts, causing the jaws or conveyed workpiece to fly out.
- Before installing the jaws, disconnect the air piping.

6-3. Connecting the air piping

The air pressure supply ports to open and close the gripper jaws are provided on the side face and rear face of the body.

When using the supply port on the side face of the body, connect the air piping directly.

When using the supply port on the rear face of the body, remove the setscrew, which is attached at the delivery to prevent air leakage, and supply air from the adapter to fix the gripper.

The screws to close the opening/closing ports on the side face of the body are to be prepared by the customer.

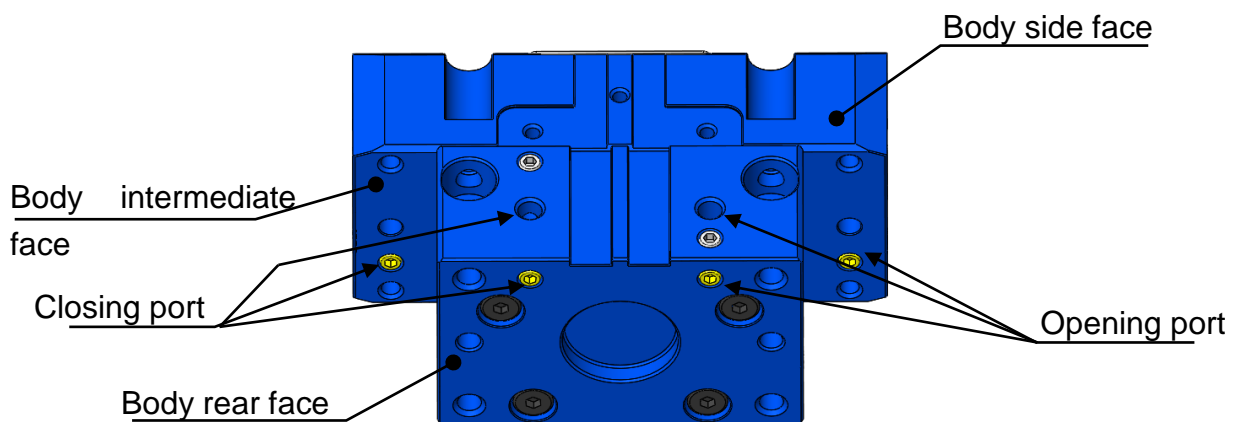

Model	NTS	206	208	210	212	216	220	230
Port size of body side face		M5	M5	M5	G1/8	G1/8	G1/8	G1/8
Port size of body rear face		M3	M4	M4	M5	M5	M6	M6
Port size of body intermediate face		M3	M4	M4	M5	M5	M5	-

NOTICE

- The setscrews in the air pressure supply ports on the body rear face are mounted with adhesive applied to them to prevent air leakage, so it is very difficult to remove them. Therefore, when removing the setscrews, be careful not to damage them.
- After removing the setscrews, take away adhesive fixed to the body screw hole clearly. Be careful not to drip the adhesive into the cylinder.
- NTS230(H)-M do not have ports of body intermediate face.

 **WARNING**

- Be sure to shut off the air pressure before connecting the air piping.
- Use compressed air as the fluid.
- Do not use compressed air that contains chemicals, synthetic oils containing organic solvents, salt, or corrosive gases, as it may cause damage or malfunction.

 **CAUTION**

- Use clean air that has passed through an air filter (filtration of 5 µm or less).
- Keep the fluid temperature and ambient temperature within the range of 5 to 60°C.
- Can be used without lubrication, but if lubricated, please use Class 1 turbine oil (no additives) ISO VG32.
- Select an after cooler, air dryer, mist separator, etc., according to ISO 8573-1 Class 4, and take measures against drainage.
- Adjust with a speed controller, etc. so that the opening/closing speed does not become faster than necessary.

6-4. Installing the switches

Use reed switches of the following models.

	CKD			SMC	
	Noncontact	2-wire system		Noncontact	2-wire system
Model	F2H	F2V	F2S	D-M9B	D-M9BV
Lead wire pull-out shape	Straight	L-shaped	L-shaped short	Straight	L-shaped

* Using reed switches not shown below may lead to unstable response.

① Installing the reed switch

Install the reed switch using the attached reed switch bracket.

When using reed switches, please design a adaptor without interference with the reed switches

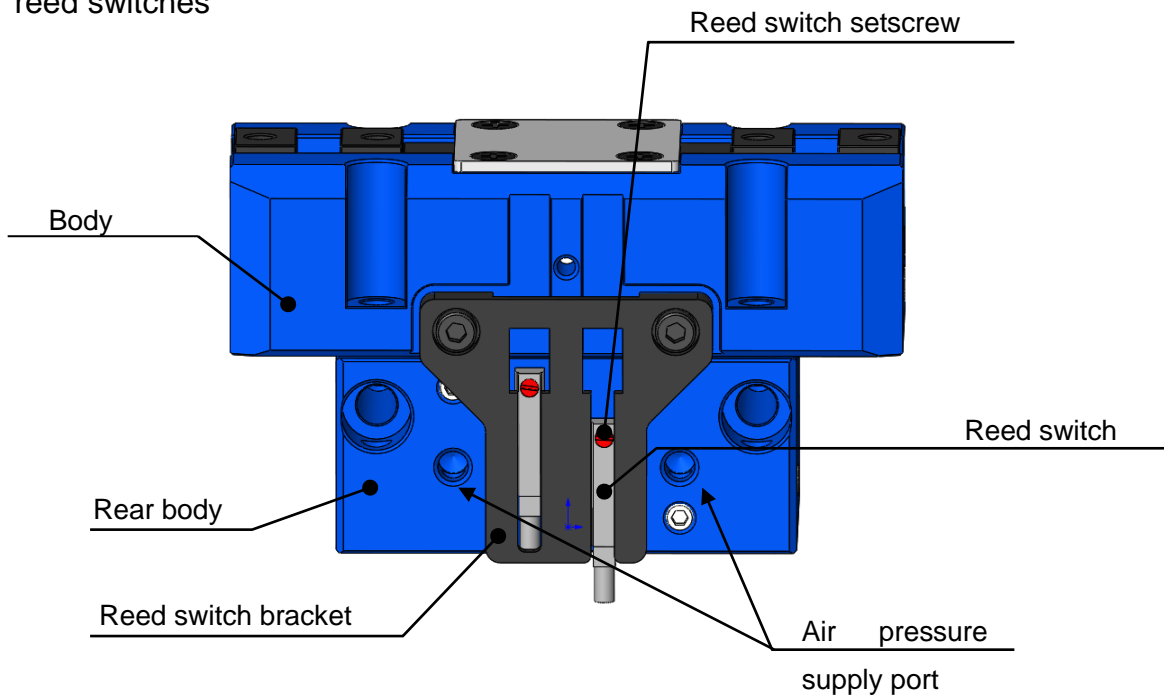

● Installation procedure for the close end side

- ① Move the master jaws to the close end positions, respectively.
- ② Install the reed switch using the reed switch bracket.
- ③ Move up and down the reed switch slowly.
- ④ Tighten and fix the setscrew provided on the reed switch at the position where the reed switch detected.
- ⑤ Repeat the opening/closing operation of the master jaws to confirm that the reed switch can detect.

*In the case of workpiece external gripping, make the above-mentioned adjustment with the workpiece gripped.

● Installation procedure for the open end side

- ① Move the master jaws to the open end positions, respectively.
- ② Install the reed switch using the reed switch bracket.
- ③ Move up and down the reed switch slowly.
- ④ Tighten and fix the setscrew provided on the reed switch at the position where the reed switch detected.
- ⑤ Repeat the opening/closing operation of the master jaws to confirm that the reed switch can detect.

② Installing the proximity switch

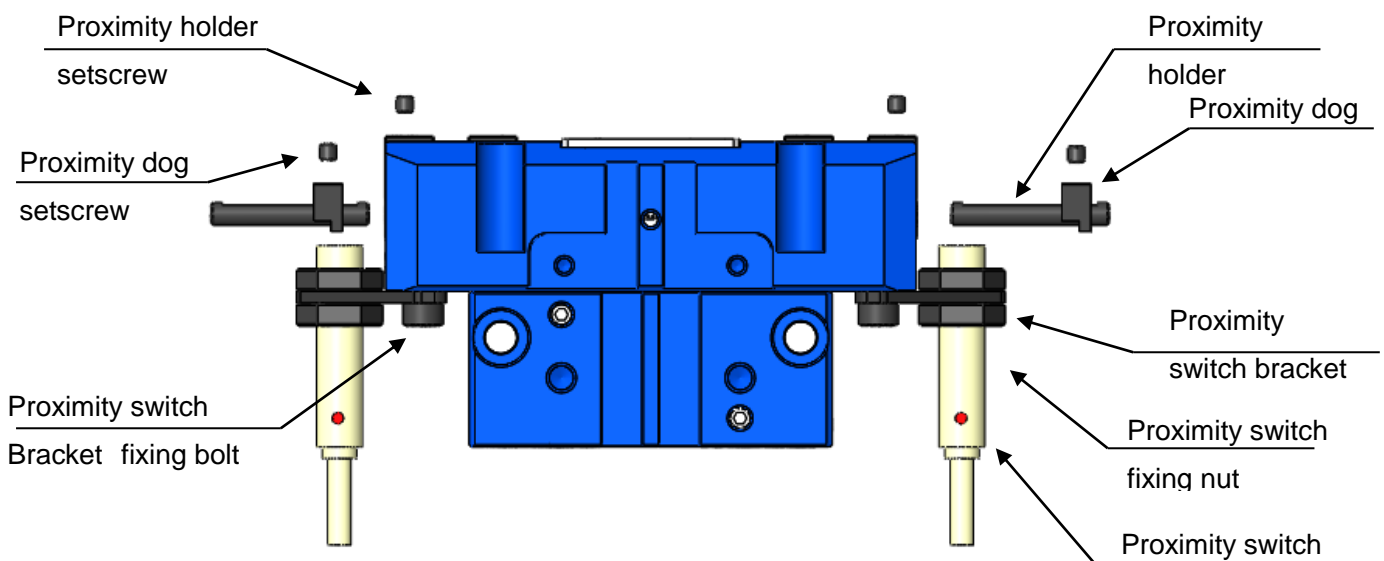

● Installation procedure for the close end side

- ① Move the master jaws to the close end positions, respectively.
- ② Install the proximity switch using the proximity switch bracket.
- ③ Install the proximity holders to the master jaws respectively, and fix them using the setscrews.
- ④ Insert the proximity holders in the proximity dogs, respectively.
Move the proximity dog to the position where the proximity switch reacts, and fix the dog with the setscrew.
* If the proximity switch does not react, adjust the distance between the proximity switch and the proximity dog.
- ⑤ Repeat the opening/closing operation of the master jaws to confirm that the proximity switch can detect the proximity dog.

- Installation procedure for the open end side

- ① Move the master jaws to the open end positions, respectively.
- ② Install the proximity switch using the proximity switch bracket.
- ③ Install the proximity holders to the master jaws respectively, and fix them using the setscrews.
- ④ Insert the proximity holders in the proximity dogs, respectively.
Move the proximity dog to the position where the proximity switch reacts, and fix the dog with the setscrew.
 - * If the proximity switch does not react, adjust the distance between the proximity switch and the proximity dog.
 - * If the distance between the proximity switch and the proximity dog cannot be adjusted in the stroke direction, change the proximity dog installation direction and adjust the distance.
- ⑤ Repeat the opening/closing operation of the master jaws to confirm that the proximity switch can detect the proximity dog.

NOTICE

- If chips enter between the proximity switch and the proximity dog, it is recommended to install a proximity switch protection cover.
- When using NTS230(H)-M, a proximity switch cannot be installed.

7. Maintenance and Checking

7-1. Periodic checking

- Before work or at the grease supply, move the jaws over full stroke to check that the stroke mentioned in the specification table is obtained.
- At the end of work, be sure to clean the gripper main body using an air gun.
- At least every three months, check that respective bolts have been tightened.

7-2. Maintenance interval

- The maintenance interval is 1 million cycles, and disassemble the gripper, and clean, replace the seals, apply grease, and reassemble the gripper.

7-3. Grease

① Grease used

- Be sure to use the specified grease listed below. If unspecified grease is used, adequate effect may not be obtained.

Brand	Manufacturer
Klueberpaste 46 MR 401	Klueber Lubrication: Whole world
CHUCK GREASE PRO	Kitagawa genuine grease (Kitagawa sales agents in each country)

② Supplying method

- ① Remove the cover (No.4).
- ② Apply grease to the fitting parts between the body (No.1), master jaw (No.5), and plunger (No.3).
- ③ Move the master jaws several strokes without gripping anything to spread the grease.

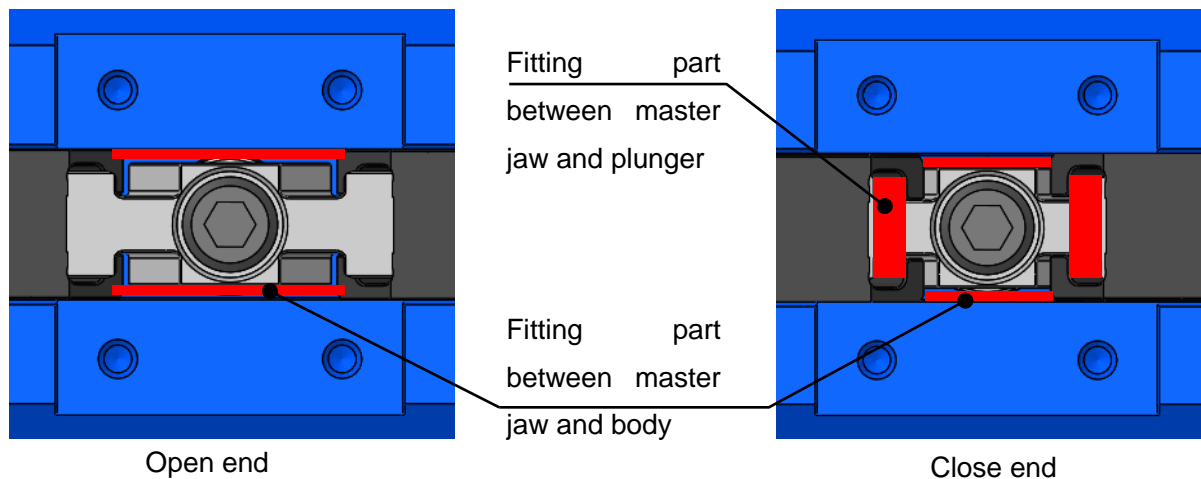

③ Safety information on grease and antitrust oil

Applicable range

- Specified grease
- Antitrust agent applied to the product at the delivery

First-aid treatment

- Aspiration: In case of much aspiration, go to a place where there is fresh air, and cover your body with a blanket to keep your body warm. Consult a doctor if necessary.
- Sticking to your skin: Wipe off the oil, and wash your skin with water and soap. If you feel itchy or you get inflamed, consult a doctor immediately.
- Entering your eye: Wash your eye with fresh water for at least 15 minutes, and then consult a doctor.
- Accidental drinking: Consult a doctor immediately without vomiting forcibly.
- For the grease other than the specified one and antitrust oil prepared by the customer, refer to the safety information prepared for respective oils.

7-4. Air circuit maintenance

- Periodically drain the air filter, etc.
- If foreign matter such as carbonized compressor oil enters the circuit, the solenoid valve and robot hand will malfunction, so be careful when performing maintenance and inspection of the compressor.

7-5. Disassembly

Disassembly procedure(NTS206)

By referring to the parts list on page 5, disassemble the product through the procedure below:

- ① Stop the air pressure supplied to the gripper and disconnect the air piping.
- ② Remove the gripper from the robot or the loader.
- ③ Remove the cover fixing bolts (No.201) and the cover (No.4).
- ④ Loosen the rear body fixing bolts (No.208) and remove the rear body (No.2).
- ⑤ Loosen the piston fixing bolts (No.200) and remove the plunger (No.3) and the master jaws (No.5).

Disassembly procedure(NTS208,NTS210,NTS212,NTS216,NTS220,NTS230)

By referring to the parts list on page 6, disassemble the product through the procedure below:

- ① Stop the air pressure supplied to the gripper and disconnect the air piping.
- ② Remove the gripper from the robot or the loader.
- ③ Remove the cover fixing bolts (No.201) and the cover (No.4).
- ④ Loosen the piston fixing bolts (No.200) and remove the plunger (No.3) and the master jaws (No.5).
- ⑤ Loosen the rear body fixing bolts (No.208) and remove the rear body (No.2).
- ⑥ Remove the piston (No.6) from the rear body (No.2).

Assembly procedure(NTS206)

By referring to the parts list on page 6, assemble the product through the procedure below:

- ① Insert the master jaws (No.5) in the body (No.1).
- ② Assemble the master jaws (No.5) and plunger (No.3), and fix the plunger (No.3) and the piston (No.6) with the piston fixing bolt (No.200).
Note 1: For the piston fixing bolt (No.200) tightening torque, refer to page 8.
Note 2: The plunger (No.3) and the piston (No.6) have phases, respectively.
Note 3: piston (No.6) Align the magnet position to the sensor groove.
- ③ Attach the parallel pin (No.206) and O-ring B (No.205) to the rear body (No.2).

- ④ Assemble the body (No.1) and rear body (No.2) using the rear body fixing bolts (No.208).
- ⑤ Fix the cover (No.4) using the cover fixing bolts (No.201).
- ⑥ Install the gripper to the robot or the loader.
- ⑦ Connect the air pressure piping.

Assembly procedure (NTS208,NTS210,NTS212,NTS216,NTS220,NTS230)

By referring to the parts list on page 6, assemble the product through the procedure below:

- ① Insert the piston (No.6) in the rear body (No.2). (Align the magnet position to the sensor groove.)
- ② Attach the parallel pin (No.206) and O-ring B (No.205) to the rear body (No.2).
- ③ Assemble the body (No.1) and rear body (No.2) using the rear body fixing bolts (No.208).
- ④ Insert the master jaws (No.5) in the body (No.1).
- ⑤ Assemble the master jaws (No.5) and plunger (No.3), and fix the plunger (No.3) and the piston (No.6) with the piston fixing bolt (No.200).

Note 1: For the piston fixing bolt (No.200) tightening torque, refer to page 8.

Note 2: The plunger (No.3) and the piston (No.6) have phases, respectively.

- ⑥ Fix the cover (No.4) using the cover fixing bolts (No.201).
- ⑦ Install the gripper to the robot or the loader.
- ⑧ Connect the air pressure piping.

To reassemble the gripper, apply the specified grease to the sliding parts and the oil treatment to the seal sliding parts, and perform the reverse procedure of disassembly while checking that the seals do not protrude or fall.

Oil treatment used

Be sure to use the specified oil treatment shown below.

Brand	Manufacturer
S-10 Oil treatment	Napolex: Japan



- Be sure to tighten the bolts with the specified torque. Lack or tightening torque or excessive torque could break the bolts, causing the conveyed workpiece to fly out.

8. Troubleshooting

8-1. Gripper is faulty

Check the following, and take corrective actions.

Symptom	Cause	Corrective actions
Gripper does not operate	Gripper internal part is broken	Replace the gripper with a new one.
	Slideways get seized	Disassemble, and correct the seized part with an oilstone, or replace the gripper with a new one.
	The piston does not operate	Check that the air pressure is within the operating pressure range
		Check for air leakage
		Check the piping and solenoid valve, and if normal, disassemble and clean the cylinder
The switch is faulty or installed incorrectly	Check that the switch can detect normally.	
Lack of master jaw stroke	Much dust exists in master jaws	Disassemble the gripper, clean it, replace the seals, and apply grease
Low gripping force	Low air pressure	Check that the air pressure is within the operating pressure range
	Air leaks from the seal	Disassemble the gripper, clean it, replace the seals, and apply grease
	Master jaw movements are not smooth	Remove the cover and supply grease, and open and close the master jaws several times without gripping any conveyed workpiece
		Disassemble the gripper, clean it, and apply grease

**WARNING**

- If the gripper failed due to a seizure or damage, disassemble the gripper following the disassembly procedure. If the gripper is in the state that you cannot disassemble, do not disassemble it forcibly but please contact us or our agents.
- Stop using the gripper immediately if the situations are not improved though corrective actions given in above table were taken. Continuous use of faulty product or part could cause serious human accidents due to flying gripper or conveyed workpiece.
- The gripper must be repaired only by skilled persons who have received the training course. Repair by unskilled persons or persons other than us or our agents could cause serious human accidents.

8-2. Contact address in case of trouble

Please get in touch with our sales agent from which you purchased the gripper or our office of the address given on the back cover when the gripper troubled.

9. Others

9-1. Standards and directives to which the gripper conforms

This product conforms to the following standards and directives:

- Machinery directive:2006/42/EC Annex I
- EN ISO 12100:2010

9-2. Disposal of gripper

Dispose of this unit in accordance with the laws and regulations of your country.