**WISE**

5軸センタリングバイス 5-axis Centering Vises

V75V シリーズ series

V75V13C ・ V75V17C

5軸マシニングセンタでの 荒加工に最適

The best partner with 5-axis machining centers for rough machining

NEW

- 最大20kNの締付力 (注1)
- 最小3.5mmの掴み代で素材底部を把握し5面加工
- 低床ボデーで広い加工範囲と良好な刃物の寄り付きを提供
- 焼き入れボデーが高い耐久性を実現
- 1台で荒加工と仕上げ加工が可能 (注2)
- ±0.01mmの繰り返し精度 (注2)

(注1) トルクレンチ、レンチ用ソケットを別途お求めください。

(注2) オプションのコンビネーションジョー使用時

- Maximum clamping force of 20kN (Note 1)
- Grips the bottom of the material with a minimum gripping length of 3.5mm for 5-axis machining
- The low-profile body provides a wide machining range and good tooling access.
- Achieving high durability with a quenched body
- Roughing and finishing can be performed with one unit (Note 2)
- Repeatability of ±0.01mm (Note 2)

(Note 1) Please purchase the torque wrench and the wrench socket separately.

(Note 2) When using the optional combination jaws

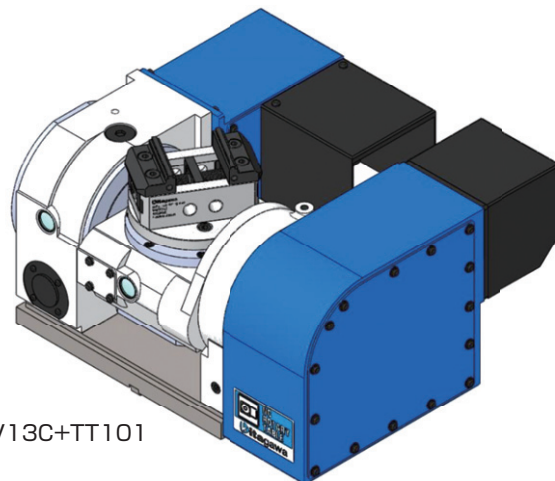

▲ V75V13C+TT101

仕様表 Specifications

(単位 Unit : mm)

型式 Model	許容最大トルク Max. input torque (N · m)	最大締付力 Max. clamping force (kN)	ジョー可動範囲 (標準グリップジョー使用時) Jaw movable range (When using standard grip jaws)	ジョー幅 Jaw width	ボデー全長 Body length	ボデー高さ Body height	質量 Mass (kg)
V75V13C	100	20	3.8 - 117	75	130	42	3.0
V75V17C	100	20	3.8 - 157	75	170	42	3.6

オプション Option

(使用方法は取扱説明書をご参照ください。)
(Please refer to the instruction manual for usage.)

標準グリップジョー Grip jaws 2pcs./set (付属品, accessories)	フラットジョー Flat jaws 2pcs./set (オプション, option)	コンビネーションジョー Combination jaws 2pcs./set (オプション, option)	平行プレート Parallel plates 2pcs./set (オプション, option)
 <p>グリップでワークをしっかり把握する荒加工用</p> <p>For rough machining that firmly grips the workpiece with grips</p>	 <p>把握部に傷が付きにくい把握面が平滑なジョー</p> <p>Jaws with smooth gripping surfaces that do not easily scratch the gripping part</p>	 <p>グリップと研削された把握面を持ち荒加工と仕上げの両方に使用</p> <p>Used for both roughing and finishing with grips and ground gripping surfaces</p>	 <p>コンビネーションジョーの研削面で把握する際のワークのかさ上げ用</p> <p>For raising the workpiece when gripping it with ground surfaces of combination jaws</p>
ストリッパボルト Stripper bolts 4pcs./set (付属品, accessories)	六角穴付き低頭ボルト Hex. Socket cap low head bolts 4pcs./set (オプション, option)	トルクレンチ Torque wrench	トルクレンチ用ソケット Wrench socket 差込角 Drive square 27mm 2面幅 Width across flats 12mm
 <p>ジョー取付用</p> <p>For mounting jaws</p>	 <p>平行プレート取付用</p> <p>For mounting parallel plates</p>		

■ ジョーストローク Jaw stroke

(単位 Unit : mm)

型式 Model	標準グリップジョー Grip jaw		フラットジョー (オプション) Flat jaw (Option)		コンビネーションジョー (オプション) Combination jaw (Option)	
	S1	S2	S3	S4	S5	S6
V75V13C	3.8-60.6	59-117	5-61.8	60.6-118.2	0[12]-56.8	55.2-113.2
V75V17C	3.8-100.6	59-157	5-101.8	60.2-158.2	0[12]-96.8	55.2-153.2

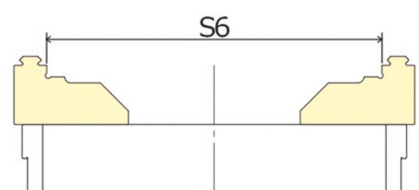
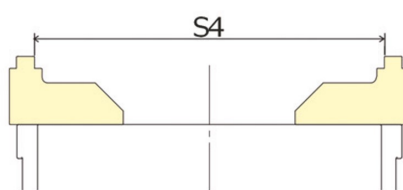
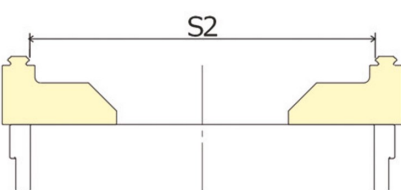
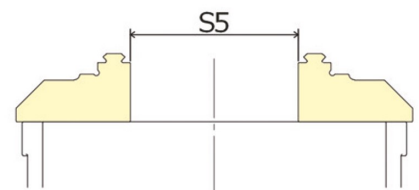
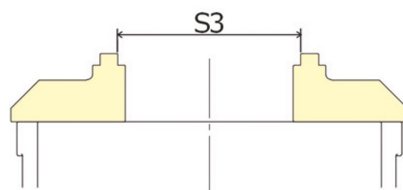
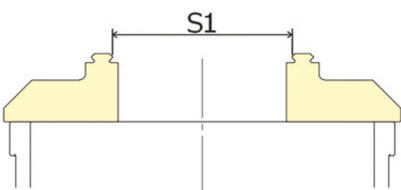

標準グリップジョー
Grip jaw

フラットジョー
(オプション)
Flat jaw
(Option)

コンビネーションジョー
(オプション)
Combination jaw
(Option)

■ 寸法図 Dimensions

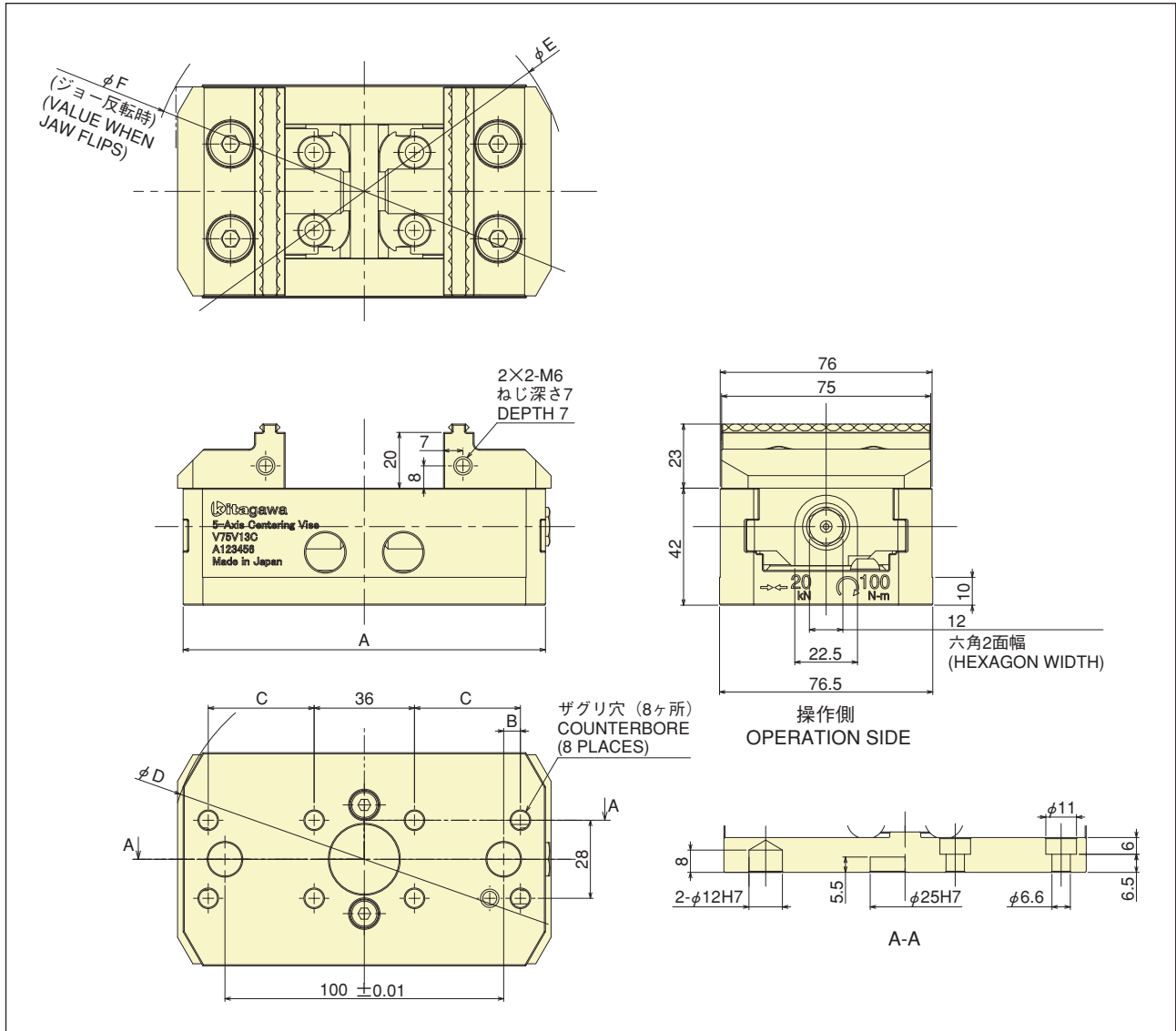

■ 寸法表 Size Table

(単位 Unit : mm)

型式 Model	A	B	C	D	E	F
V75V13C	130	6	38	140	146	155
V75V17C	170	26	58	177.8	183	191

