

INSTRUCTION MANUAL

M-H type

ROTARY HYDRAULIC CYLINDER CLOSED CENTER



- This instruction manual is for production engineers and maintenance personnel in charge of operation of this product. When a beginner uses this product, receive instructions from experienced personnel, the distributor or our company.
- Before installing, operating or maintaining this equipment, carefully read this manual and the safety labels attached to the equipment. Failure to follow these instructions and safety precautions could result in serious injury, death, or property damage.
- Store this manual near equipment for future reference.
- If any questions related to safety arise about this manual, please confirm them with the distributor or our company.

Kitagawa Corporation

77-1, Motomachi, Fuchu-shi, Hiroshima, 726-8610, Japan

TEL +81-(0)847-40-0526

FAX +81-(0)847-45-8911

Preface

This manual provides detailed information about how to safely and correctly use the cylinder (M·H type, 09 size is M·R type) for a lathe.

Before starting to use this cylinder, read this manual carefully and always follow the instructions and warnings in "Important Safety Precautions" and "Precautions for Use" at beginning of the manual. Failure to follow these precautions could result in a serious accident.

Terms and Symbols Used for Safety Messages

In this manual, precautions for handling that are considered especially important are classified and displayed as shown below depending on the damage of risk including the seriousness of the harm that could result. Please sufficiently understand the meanings of these terms and follow the instructions for safe operation.

Safety Alert Symbol

The triangle is the safety alert symbol used to alert you to potential safety hazards that could result in injury or death.



Indicates a hazardous situation which, if you not avoided, will result in death or serious injury.



Indicates a hazardous situation which, if you not avoided, could result in death or serious injury.



Indicates a hazardous situation which, if you not avoided, could result in minor or moderate injury.



Indicates instructions which, if not avoided, could result in damage to the equipment or a shortened work life.

Liability and How to Use this Manual

This product is a hydraulic device to control the operation of power chuck installed on the lathes or rotary tables. For any other applications, please contact us.

Our company will not assume responsibility for injury, death, damage, or loss resulting from not following the instructions in this manual.

There are countless things that cannot or should not be done, and it is impossible to cover all of them in this manual.

Therefore, do not perform any actions unless they are specifically allowed in this manual. If any questions related to safety arise about operation, control, inspection and maintenance which are not specified in this manual, please confirm them with our company or distributor before performing them.

Guarantee and Limitation of Liability

The guarantee period of this product is 1 year after delivery.

Use the parts delivered by Kitagawa Corporation for all the parts including consumable parts. We will not assume responsibility for injury, death, damage, or loss caused by usage of parts not manufactured by Kitagawa Corporation. Additionally, if parts other than genuine parts manufactured by Kitagawa Corporation are used, this guarantee will be completely invalid.

The chuck and cylinder from Kitagawa Corporation should be used together. If you must use a part not made by Kitagawa, check with us or our distributor to be sure it is safe to do so. We will not be responsible for injury, death, damage or loss caused by use of a chuck or cylinder made by another company unless this use has been approved by Kitagawa or its distributor.

Table of Contents

1. Structural Drawing and Parts List -----	5
1-1. Type display	
1-2. Structural drawing	
1-3. Scope of product	
1-4. Parts list	
2.  Important Safety Precautions -----	13
3. Specifications -----	20
3-1. Specification table	
4. Hydraulic Oil-----	21
5. Trial Operation-----	23
6. Proximity switch-----	25
6-1. Specification	
6-2. Adjusting the position of a proximity switch	
7. Maintenance and Inspection-----	27
7-1. Maintenance and inspection of cylinder	
7-2. Maintenance and inspection of hydraulic unit	
7-3. List of seals to use	
7-4. Special instructions	
8. Malfunction and Countermeasures-----	31
8-1. In the case of malfunction	
8-2. Where to contact in the case of malfunction	

For Machine Tool Manufacturers (Chapter 9)

9. Attachment-----	33
9-1. Outline drawing of attachment	
9-2. Production and attachment of cylinder adapter	
9-3. Production and attachment of draw bar	
9-4. Attachment of cylinder	
9-5. Tightening torque of cylinder attaching bolt	
10. About Hydraulic Circuit Design-----	44
11. Other Information -----	47
11-1. About standards and orders	
11-2. Information about markings of product	
11-3. About disposal	

1. Structural Drawing and Parts List

1-1. Type display

Type display as shown below

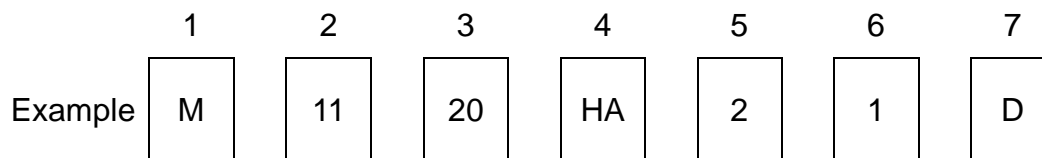

1. M Abbreviated name of M cylinders
2. 11 Nominal inside diameter of the cylinder
3. 20 Nominal piston stroke
4. HA Inner air type (M09 type is RA)
HB Inner coolant type
HC None
- 5~7 Columns for special specification

1-2. Structural drawing

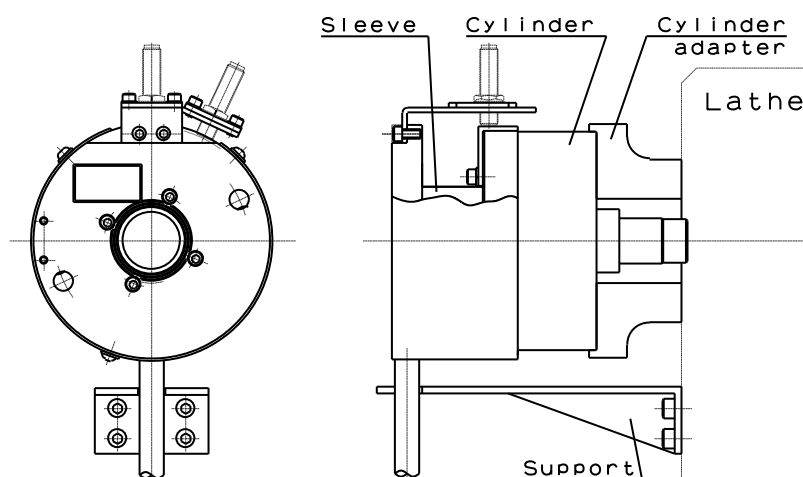

Fig. 1

Note) Proximity switch is not included.
Please prepare by yourself.

1-3. Scope of product

This instruction manual is for the cylinder part.

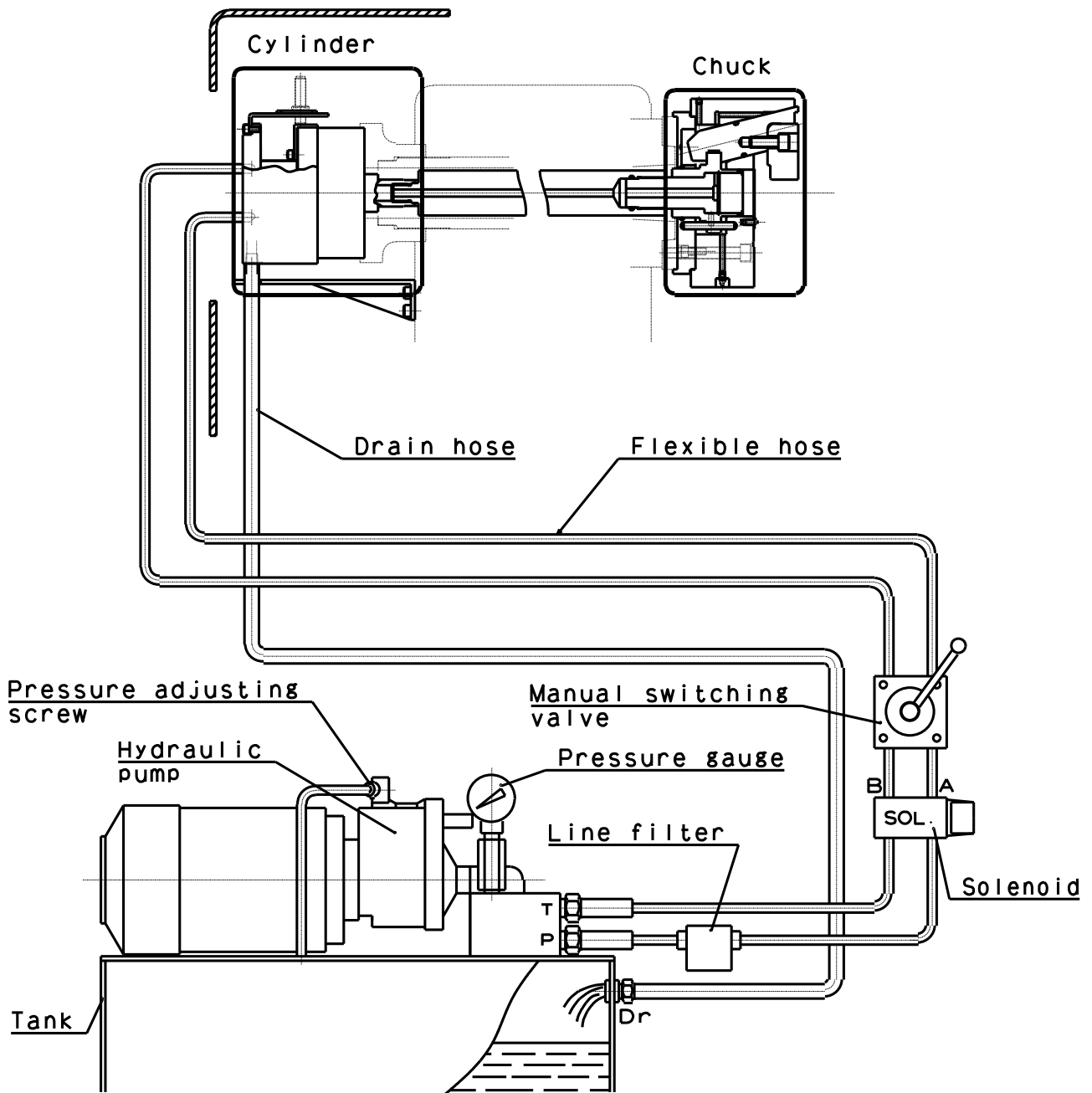

Fig. 2

! WARNING

- To prevent the work from flying, safe design, maintenance and erroneous action prevention of the hydraulic system to maintain the gripping force of the chuck is extremely important. Thoroughly read the "Important Safety Precautions" on and after page 13 in this manual.
- As for the chuck, follow the instruction manual for the chuck.

1-4. Parts list

-HA(M09 type is RA) type

M0915RA

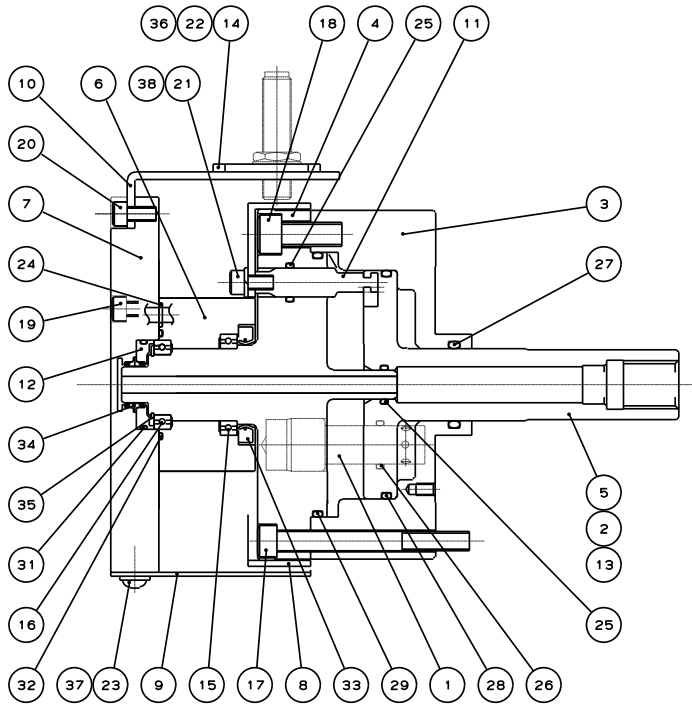

M1120HA21D, M1221HA21D, M1330HA21D

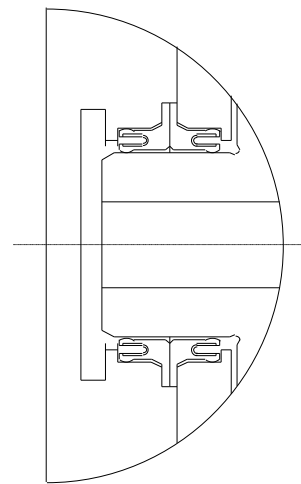
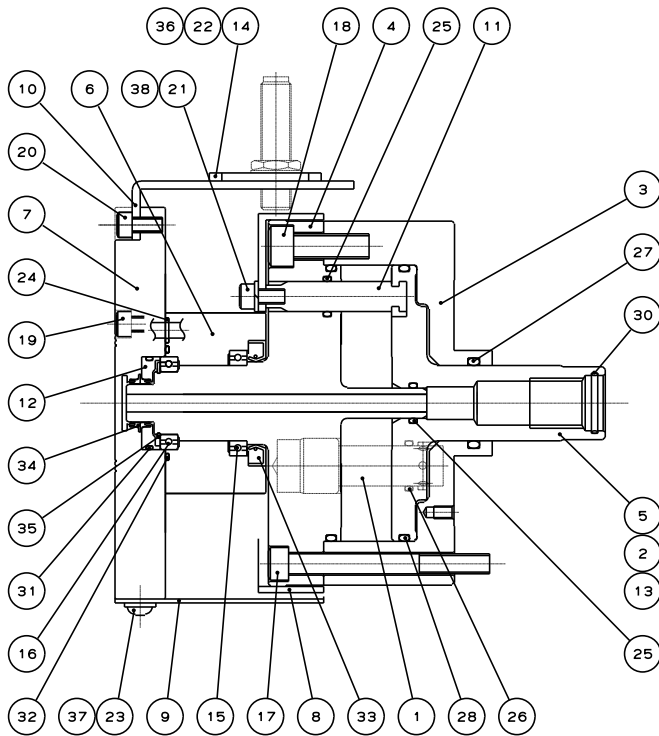

Detail of Teflon seal

Fig. 3

Table 1

No.	Part name	Quantity	No.	Part name	Quantity
1	Lock valve	2	19	Socket head cap screw	4
2	Relief valve	2	20	Socket head cap screw	2
3	Cylinder	1	21	Socket head cap screw	2
4	Rotary valve	1	22	Socket head cap screw	4
5	Piston	1	23	Socket button head cap screw	3
6	Sleeve	1	24	O-ring	3
7	Sleeve cover	1	25	O-ring	3
8	Detectable plate	1	26	O-ring	2
9	Ring	1	27	O-ring	1
10	Bracket	1	28	O-ring	2 (M0915RA:1)
11	Slide pin	2	29	O-ring	1 (M0915RA only)
12	Shim ring	1	30	O-ring	1 (M0915RA:0)
13	Spacer	M0915RA : 1	31	O-ring	1
		M1120HA21D : 1	32	O-ring	1
		M1221HA21D : 0	33	Oil seal	1
		M1330HA21D : 2	34	Teflon seal	2
14	Adjusting plate	2	35	Retaining ring	1
15	Bearing	1	36	Washer	4
16	Bearing	1	37	Washer	3
17	Socket head cap screw	6	38	Washer	2
18	Socket head cap screw	6			

•HB type

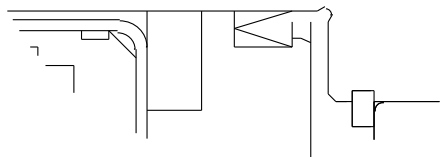
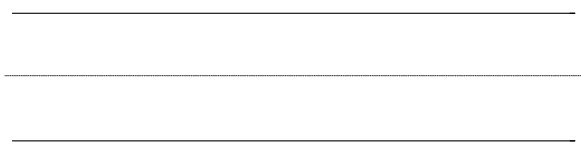
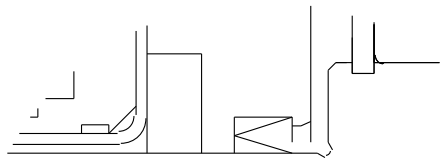
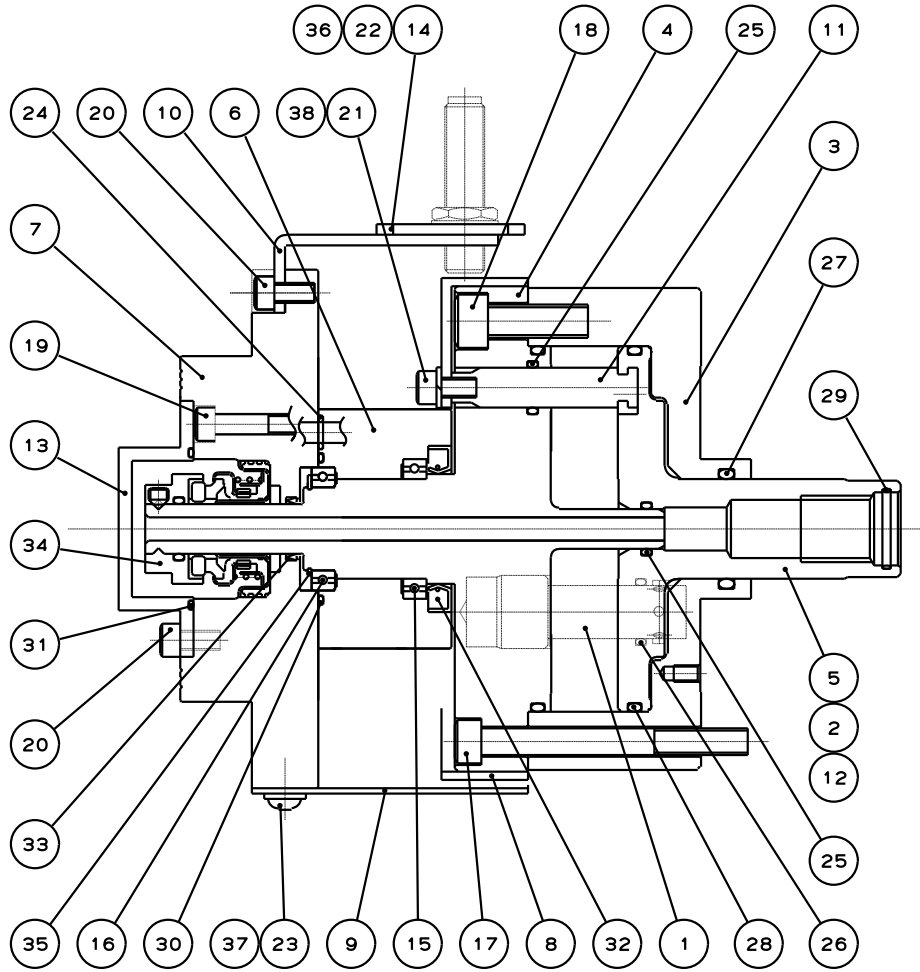

Detail of Teflon seal

Fig. 4

Table. 2

No.	Part name	Quantity	No.	Part name	Quantity
1	Lock valve	2	19	Socket head cap screw	4
2	Relief valve	2	20	Socket head cap screw	6
3	Cylinder	1	21	Socket head cap screw	2
4	Rotary valve	1	22	Socket head cap screw	4
5	Piston	1	23	Socket head cap screw	3
6	Sleeve	1	24	O-ring	3
7	Sleeve cover	1	25	O-ring	3
8	Detectable plate	1	26	O-ring	2
9	Ring	1	27	O-ring	1
10	Bracket	1	28	O-ring	2
11	Slide pin	2	29	O-ring	1
12	Spacer	M1120HB21N : 1	30	O-ring	1
		M1221HB21N : 0	31	O-ring	1
		M1330HB21N : 2	32	Oil seal	1
13	Cover	1	33	Teflon seal	1
14	Adjusting plate	2	34	Mechanical seal	1
15	Bearing	1	35	Retaining ring	1
16	Bearing	1	36	Washer	4
17	Socket head cap screw	6	37	Washer	3
18	Socket head cap screw	6	38	Washer	2

•HC type

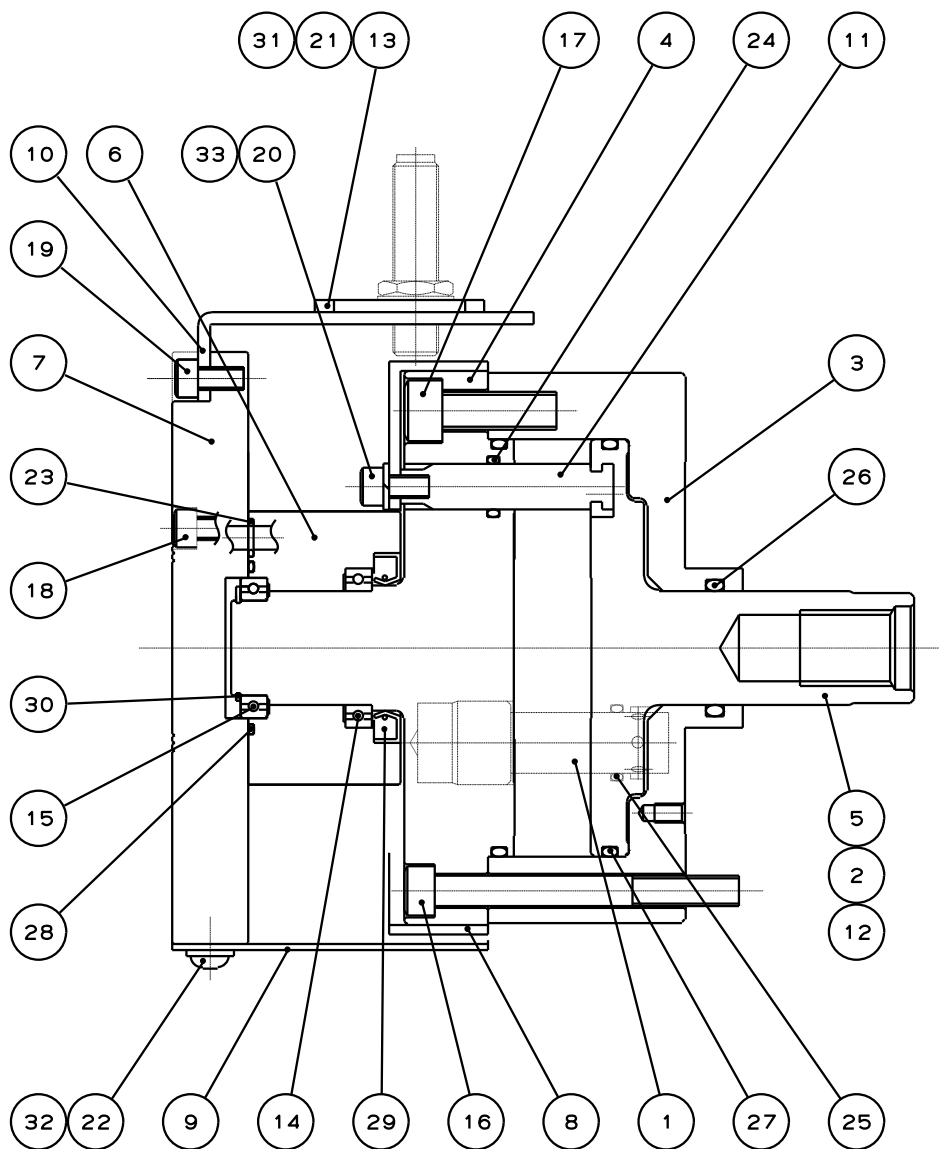



Fig. 5

Table 3

No.	Part name	Quantity	No.	Part name	Quantity
1	Lock valve	2	17	Socket head cap screw	6
2	Relief valve	2	18	Socket head cap screw	4
3	Cylinder	1	19	Socket head cap screw	2
4	Rotary valve	1	20	Socket head cap screw	2
5	Piston	1	21	Socket head cap screw	4
6	Sleeve	1	22	Socket button head cap screw	3
7	Sleeve cover	1	23	O-ring	3
8	Detectable plate	1	24	O-ring	2
9	Ring	1	25	O-ring	2
10	Bracket	1	26	O-ring	1
11	Slide pin	2	27	O-ring	2
12	Spacer	M1120HC21D:1	28	O-ring	1
		M1221HC21D:0	29	Oil seal	1
		M1330HC21D:2	30	Retaining ring	1
13	Adjusting plate	2	31	Washer	4
14	Bearing	1	32	Washer	3
15	Bearing	1	33	Washer	2
16	Socket head cap screw	6			

2. Important Safety Precautions

Important safety precautions are summarized below. Please read this section before first starting to use this product.

 **DANGER** Failure to follow the safety precautions below will result in serious injury or death.



Turn off main power supply before attaching, inspecting or replacing cylinder, and before adding oil.

For All Users

- The cylinder may start rotation suddenly, and a part of the body or clothing may be caught.

Main power supply

OFF

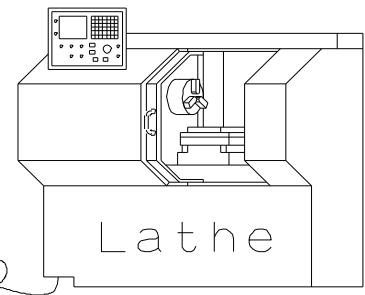
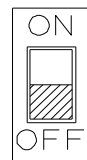

Close door before rotating spindle.

For All Users

- If the door is not closed, you may touch the rotating chuck or the work may fly out, which is very dangerous. (In general, the safety interlock function which allows rotation only when the door is the manual mode or the test mode)

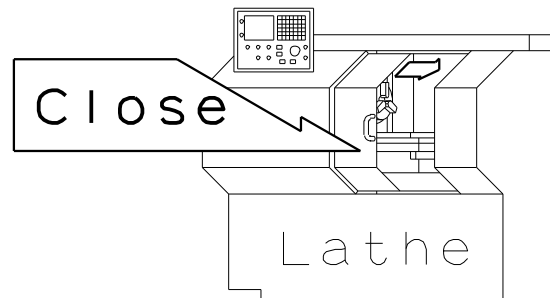

During spindle rotation, do not turn off hydraulic pump power supply and do not operate switching valve.

For All Users

- Cutting off hydraulic pressure causes a drop in the gripping force which could result in the work being released and flying out.
- Operating the manual switching valve or solenoid valve will lead to a drop of hydraulic pressure.

Manual switching valve

Jaw closed

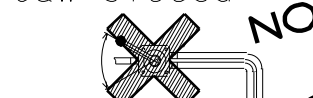

Jaw open

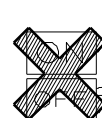

Solenoid valve

Work

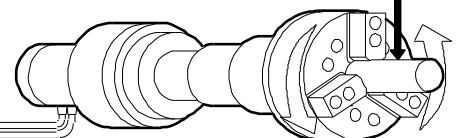



Important Safety Precautions



DANGER Failure to follow the safety precautions below will result in serious injury or death.



Do not allow the rotation speed of the chuck to exceed the maximum allowable speed limit.

For All Users

- If the rotation speed of the chuck exceeds the rotation speed limit, this is very dangerous as the chuck and work will fly out.

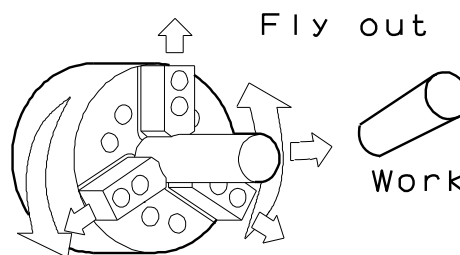

The input force of the chuck (piston thrust, pulling force of the draw bar) must not exceed the allowable maximum input force.

For All Users

- Input must match the specification of the chuck.
- Adjust the hydraulic pressure to the cylinder so that the input, which determines the gripping force of the chuck, does not exceed.
- Excessive input force can lead to breakage of the chuck, which is very dangerous, as the chuck and work can be damaged and fly out.

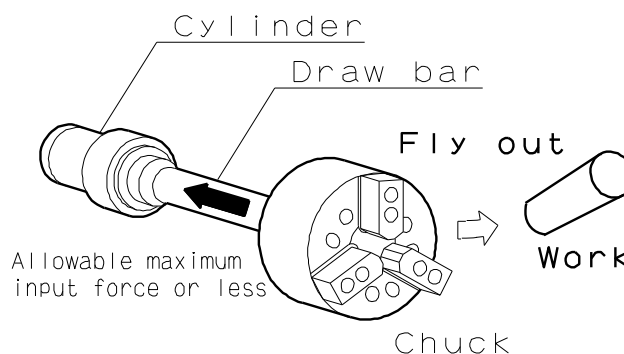

Be sure cover is attached to periphery of cylinder before operating machine. (Refer to pages 33-34)

For All Users

- This will prevent the body or clothing from being caught in the machine.

Prepare the covers that conform to the following standards.

- EN953
- EN ISO13857
- EN1088

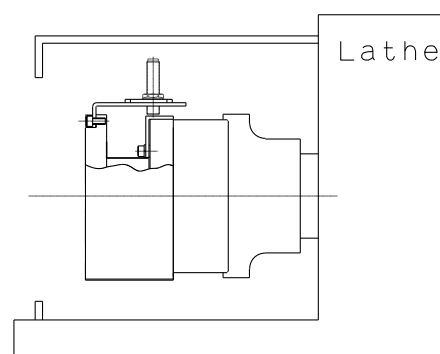



Important Safety Precautions



DANGER Failure to follow the safety precautions below will result in serious injury or death.



Always tighten the bolts at the specified torque. Use the bolts attached to the cylinder, and do not use bolts other than these. (Refer to pages 43)

For All Users

- If the torque is insufficient or excessive, the bolt will break, which is dangerous as the cylinder or work will fly out.
- Fix the lathe spindle or the cylinder when you tighten bolts. Your hand could slip and get injury when you work without fixing the spindle.
- You must use a torque wrench for torque control.

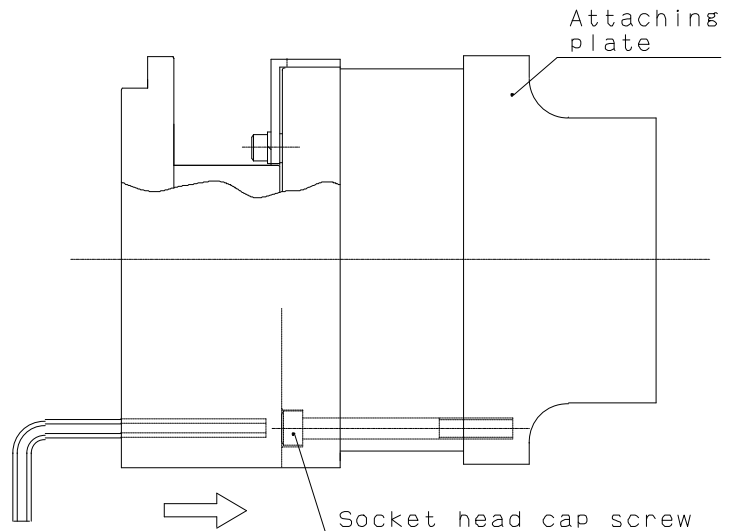

Specified torque for socket head cap screw

Bolt size	Tightening torque
M8	33 N·m
M10	73 N·m

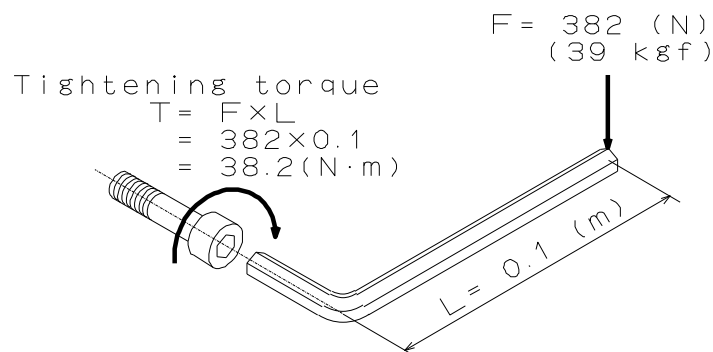

Tightening torque is moment of force when you tighten a bolt. Tightening torque = $F \times L$.



Important Safety Precautions



DANGER

Failure to follow the safety precautions below will result in serious injury or death.



Use of a chuck and cylinder that cannot be used together safely may cause the cylinder to break at high pressure resulting in the chuck and work flying out.

For All Users

- Check that the chuck and the cylinder are in the “safe combination” when using at high pressure with our company or the distributor. Especially when the cylinder of our company and a high pressure chuck of other company are combined, confirmation is necessary.
- If one of the abnormal events shown below occurs during operation, immediately stop the machine and consult with our company or the distributor.
 - The work slips.
 - Loss of accuracy.
 - The work begins to chatter.
 - The machine's vibration significantly increases.

The gripping force does not rise even if hydraulic pressure is raised.

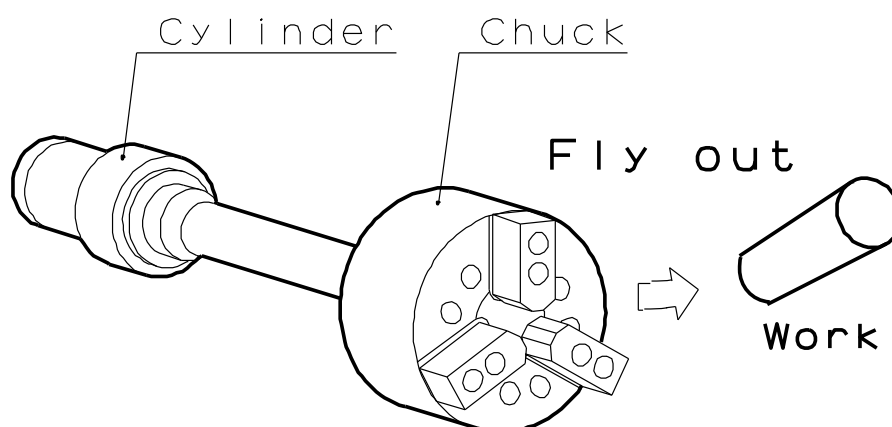



Important Safety Precautions



DANGER Failure to follow the safety precautions below will result in serious injury or death.



Provide sufficient strength for the draw bar (Refer to pages 37-39).

Provide sufficient screw depth for the draw bar.

Firmly tighten the draw bar.

Apply adhesive to the thread part of the draw bar and screw it in at the specified torque.

For Machine Tool Manufacturers

- If the draw bar break, the gripping force is instantly lost and this is dangerous as work will fly out.
- If the screw depth of the draw bar is insufficient, the screw will break and the gripping force will be lost instantly, and this is dangerous as work will fly out.
- If the draw bar is unbalanced, excessive vibration could occur breaking the screw and resulting in the gripping force being lost and the work flying out.
- When screwing the draw bar, piston to the end of the pressing side stroke.
- If the engagement of the screw of the draw bar is loose, vibration may occur resulting in breakage of the screw. If the screw breaks, the gripping force will be lost instantly, which is dangerous as the work will fly out.
- When the screw is loosened, the jaw stroke of the chuck becomes shorter and this is very dangerous as the work will fly out.

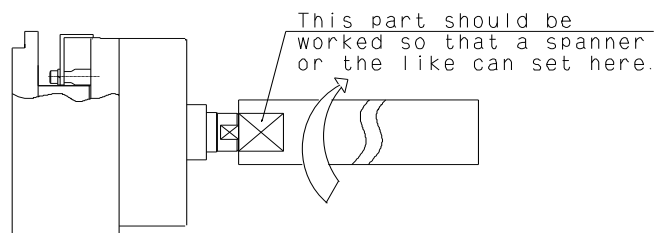
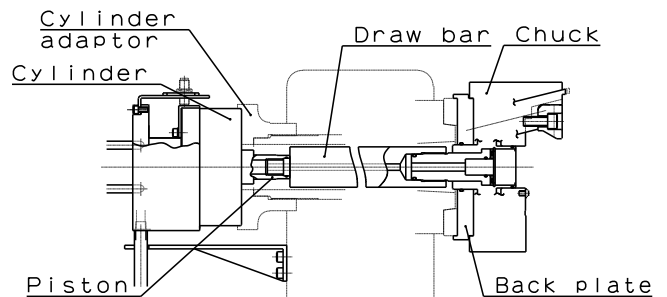

Type	Tightening torque
M0915	100 N•m
M1120	100 N•m
M1221	100 N•m
M1330	180 N•m



Important Safety Precautions



WARNING Failure to follow the safety precautions below could result in serious injury or death.



Do not modify the cylinder.

For All Users

- Doing so may damage the cylinder and cause oil leakage which could result in a fire. And if the hydraulic oil leaks, the gripping force of the chuck will lower and the work may fly out, which is dangerous.
- Do not attach additional machining such as screw.
- Do not detach parts of the cylinder from the cylinder.



Do not rotate the cylinder without hydraulic pressure.

For All Users

- Doing so could cause seizing inside the cylinder, leading to a drop in the gripping force of the chuck. This is dangerous as work will fly out.



Periodically add hydraulic oil.

Turn off power and use designated hydraulic oil. (Refer to page 21)

For All Users

- If supplying of the hydraulic oil is insufficient, the operation speed may lower and the thrust force will become insufficient resulting in a drop in the gripping force of the chuck, which is dangerous as the work may fly out.
- Use abrasion resistant and deforming hydraulic oil.

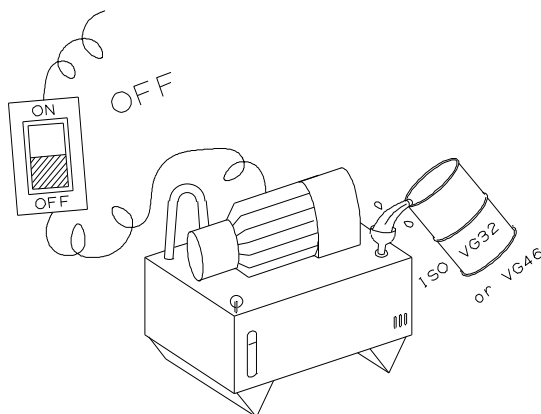



Important Safety Precautions



WARNING

Failure to follow the safety precautions below could result in serious injury or death.



Assemble piping after completely removing the dust inside the pipe.
Add a filter of 20µm or less into the pressure supplying line(P).

For All Users

- Failure to do so could cause oil leakage and may result in a fire.
- Maintain the function of the incorporated lock valve and relief valve, and prevent seizing due to foreign matter.

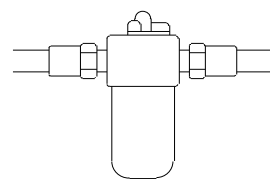

Filtering
Precision
20µm or
less

- If the function of the lock valve lowers, this is dangerous as the work will fly out when the hydraulic pressure suddenly lowers due to blackout or malfunction of the hydraulic pump, etc.
- If the function of the relief valve lowers, the volume of the filled hydraulic oil changes causing an increase in pressure, which is dangerous resulting in malfunction.
- If seizing is caused by foreign matter, the gripping force of the chuck will lower, which is dangerous as the work will fly out.



Do not operate the machine after drinking alcohol or taking medication.

For All Users



Do not operate the machine wearing gloves, a necktie, and other loose clothing or jewelry.

For All Users

- Dangerous since these lead to operation mistakes and misjudgment.

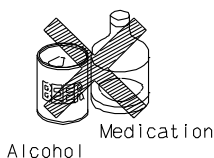

Alcohol Medication

- Dangerous since it will be caught.



Do not attach the other than parts manufactured by Kitagawa Corporation to the cylinder. (Refer to pages 7-12, Fig.3-5)

For All Users

- Doing so may damage the cylinder and cause oil leakage which could result in a fire. And if the hydraulic oil leaks, the gripping force of the chuck will lower and the work may fly out, which is dangerous.

3. Specifications

3-1. Specifications table

Table 4

Type			M0915RA	M1120HA21D	M1221HA21D	M1330HA21D
				M1120HB21N	M1221HB21N	M1330HB21N
				M1120HC21D	M1221HC21D	M1330HC21D
Piston stroke	mm		15	20	21	30
Piston surface area	Push	cm ²	64.7	87.6	105.7	125.3
	Pull	cm ²	59.8	83.9	101	118.5
Piston maximum thrust force	Push	kN	21.0	28.5	39.6	47.0
	Pull	kN	19.4	27.3	37.9	44.4
Maximum operating hydraulic pressure	MPa		3.5	3.5	4.0	4.0
Maximum rotation speed	min ⁻¹		6000	6000	6000	6000
Mass	kg		8.4	HA: 8.2	HA: 10.2	HA: 10.3
				HB: 8.5	HB: 10.5	HB: 10.6
				HC: 8.2	HC: 10.2	HC: 10.3
Moment of inertia	kg·m ²		0.016	0.016	0.028	0.029
Drain amount	ℓ/min		1.2	1.2	1.2	1.2
Balance quality	G6.3					
Storing temperature / Operating temperature	-20 ~ +50 °C / -10 ~ +40 °C					

Note 1) The drain amount is a value when the hydraulic pressure is 3.0 MPa, and the oil temperature is 50°C.

Note 2) How to obtain the piston thrust force

$$\text{Operating Piston thrust force (kN)} = \text{Piston Maximum Thrust force (kN)} \times \frac{\text{Operating hydraulic pressure (MPa)} - 0.25}{\text{Maximum operating hydraulic pressure (MPa)} - 0.25}$$

Note 3) When storing this product, the product should be subjected to the antirust treatment and stored in a place free from wetting, condensation, or freeze.

4. Hydraulic Oil

- To keep good operation of the cylinder, it is recommended to use hydraulic oil with a viscosity of 32cSt at 40°C. (ISO VG32 equivalent product)
- Replace the hydraulic oil about once every six months.
- The characteristics of hydraulic oil influences the heating, drain amount and acting speed of the cylinder, therefore, control it according to the instruction manual for the hydraulic unit.

WARNING

- **Turn off the power source and supply designated hydraulic oil. Insufficient oil supply decreases the acting speed, causes thrust force insufficiency resulting in a drop in the chuck gripping force, which could allow the work to fly out. Use abrasion resistant and deforming hydraulic oil. Add a filter of 20µm or less in the pressure supply line(P) to maintain the function of the cylinder and to prevent seizing caused by foreign matter.**

NOTICE

- If high speed rotation is continued, the oil temperature will rise, which could rapidly a high temperature, it will rapidly aggravate deterioration of the sealing materials and deterioration of the hydraulic oil. Use a cooler to keep the oil temperature at 60°C or lower.

<Example>

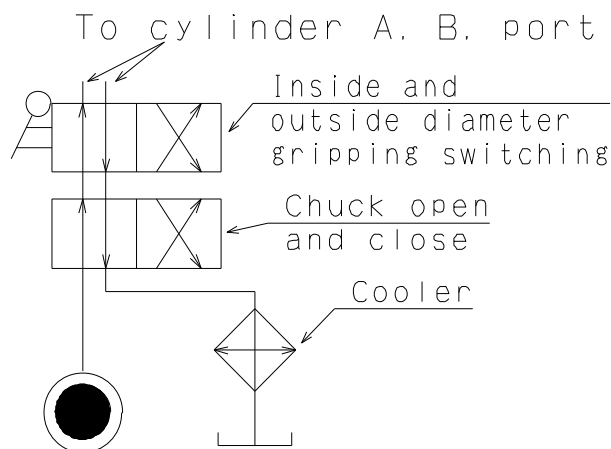

Fig. 6

※ Keep the back pressure extremely low in this case as well.

Safety information about hydraulic fluid and anti-rust oil

Applicable range

- Hydraulic fluid sealed in the product at the delivery.
- Antirust agent applied to the product at the delivery.

First aid measures

After inhalation: Remove victim to fresh air. If symptoms persist, call a physician.

After contact with skin: Wash off with mild cleaners and plenty of water. If symptoms persist, call a physician.

After contact with eyes: Rinse with plenty of water. If symptoms persist, call a physician.

After ingestion: If large amounts are swallowed, do not induce vomiting. Obtain medical attention.

- Please refer to each MSDS about the hydraulic fluid and the anti-rust oil which you prepared.

5. Trial Operation

Read safety precautions starting on page 13 before performing trial operation.

- (1) Check that the power voltage is at the specified voltage.
- (2) Set the pressure adjusting handle to the lowest state during trial operation, and check the turning direction of the pump in inching (shortly turn on and off the switch). When it is rotating in the reversed direction, change the connection of 2 cables out of the 3 cables.
- (3) As for the operating pressure for chucking, first lower to the lowest pressure, and then set to low pressure at which the chucking action is possible (0.35-0.5MPa) to check the following.
 - Is it operating smoothly?
 - Is the operating direction correct? (Opening and closing direction of the chuck)
 - Is the operating stroke appropriate? (Jaw stroke of the chuck)
 - Is there any oil leakage with each piping?If they are normal, gradually raise the operating pressure up to the rated pressure while checking the items specified above.
At this point, check that the drainage is flowing smoothly.
- (4) Rotate the lathe spindle by setting the rotation speed to the minimum. If there is no run-out of the cylinder or no abnormalities in the support and piping, gradually raise the rotation speed.
If the rotation vibration is too excessive, run-out of the adapter must be inspected again.
- (5) If the oil temperature is low (20-30°C) or less, run it in at about 1/3 of the maximum rotation speed.

NOTICE

- When the ambient temperature of the cylinder suddenly rises, for example, thermal effect is received from heating of the pulley, etc., or when there is a special heat generation source around the cylinder, the cylinder charged pressure rises and then the cylinder may stop operation, if it is continuously operated for a long period of time without switching operation, since a lock mechanism is built in such a phenomenon occurs more frequently especially at the time of running in, therefore, frequently reciprocate the piston.

< Treatment when the cylinder cannot be operated >

○ Regardless of trial operation or normal operation, when the cylinder cannot be operated, try the operations specified below.

1. When the lathe spindle is rotating, stop rotation.
2. Turn the pressure adjusting handle of the pressure regulation valve for the chuck setting pressure (cylinder setting hydraulic pressure) at the hydraulic unit part, and raise the chuck setting pressure for about 0.5 MPa and repeat switching over the operation selecting switch of the cylinder to check the operation of the cylinder.
3. If the operation inability still continues, raise the chuck setting pressure additionally (about 0.5 MPa at a time), and repeat the operation in the same manner as item (2), to check the action of the cylinder. In this case, the limit of the pressure raising is up to 30% increase of the maximum operating hydraulic pressure.
When the cylinder operation is recovered, bring back the preset chuck pressure to the normal level.
4. If the cylinder cannot be operated even after the chuck setting pressure is raised to the maximum and the operation specified in the above item (3) is repeated several times, return to the chuck setting pressure, turn off the power supply, cool down the temperature of the cylinder surface to be almost the same as the room temperature, and then repeat the operations specified in the above items (2) and (3) to check the operation of the cylinder.
The cylinder can be cooled down more quickly by forcibly blowing air to the cylinder using an air gun, etc.
5. If the cylinder cannot be operated even after cooling down, loosen the draw nut on the chuck side and remove the connection, and then check the operation of the cylinder.

< Usage >

This product is a hydraulic device to control the operation of power chuck installed on the lathes or rotary tables.

The piston moves forward and backward by supplying hydraulic pressure to the cylinder. By this, the linked jaws of the power chuck move toward the closing side to grip the workpiece, so that the workpiece is clamped during the machining. After the machining, the jaws move toward the open side to allow the workpiece to be removed.

6. Proximity switch

6-1. Specification

- A proximity switch can be attached to the M·H type (09 size is M·R) cylinder to electrically check the piston stroke and detect clamp / unclamp of the workpiece. If detection other than clamp/unclamp is required, please consult our company.
- To satisfy the requirements of European Standard "EN1550: 1997+A1: 2008 Safety requirements for the design and construction of work holding chucks", it is necessary to attach a device which ensures that the gripping force of the stroke checking proximity switches, etc. effectively operates. Because the proximity switches is not attached to the cylinder of standard specification, please arrange separately when necessary.

Table 5

Type	BES M12MI-PSC20B-BV02 (BALLUFF)
Voltage	24V DC
Leakage current	200mA or less
Operation style	PNP
Thread size	M12×1.0

Table 6

Type	BES M12MI-PSC20B-BV02 (BALLUFF)
SQ61	BLACK
+V	BROWN
0V	BLUE
SQ60	BLACK

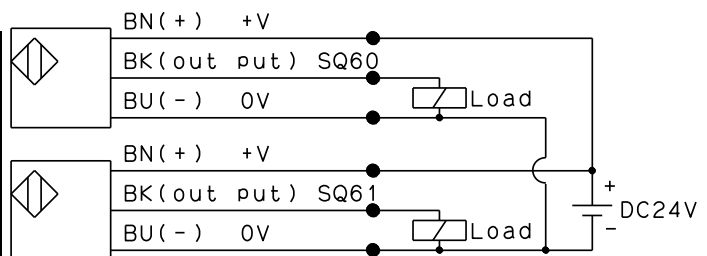

Fig. 7

6-2. Adjusting the position of a proximity switch

Read following instruction when you adjust the proximity switch. (Fig.8)

- ① Loosen the socket head cap screw [22] that fix the adjusting plate [14].
- ② Unclamp the chuck.
- ③ Install one proximity switch, passing through the adjusting plate [14], and make it approach to the detectable plate [8] until the LED of proximity switch lights up. At this time, adjust the screw of proximity switch so that the distance between proximity switch and outside diameter end of detectable plate [8] is about 1 mm, and slide to adjust the adjusting plate [14] in the axial direction.
- ④ Tighten the socket head cap screw [22] to fix the adjusting plate [14].
- ⑤ Grip the workpiece.
- ⑥ For another proximity switch proceeds in the same way as it is described from point 4 and 5.
- ⑦ Confirm whether LED lights up by opening and closing the chuck several times.

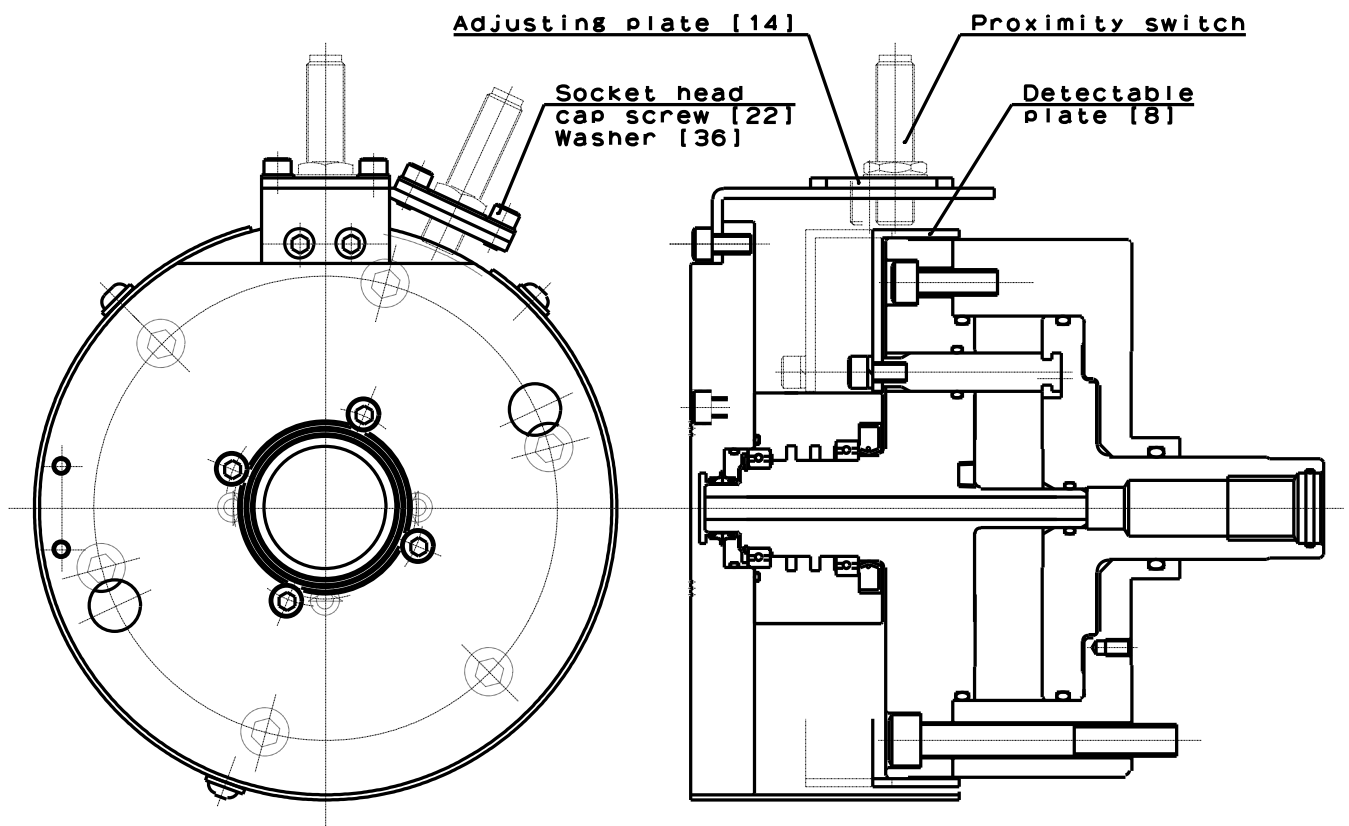

Fig.8

7. Maintenance and Inspection

7-1. Maintenance and inspection of the cylinder

- If any malfunction occurs, return cylinder to our company for repair. If it is disassembled and reassembled at a place other than our company, it may not function correctly as well as cause precision failure.
- If rust or mist adheres to the gap between the detectable plate and the rotary valve, the sliding resistance will increase and the detectable plate may be damaged. Check the gap between the detectable plate and the rotary valve for sticky substances about once a year. If there is sticky material, clean it and remove it. Follow the procedure below for cleaning. (Please refer to 1-4. Parts list on pages 7 and 8). Removing parts, make a matching mark on each part as a mark when reassembling.
 - ① Move the cylinder to the back end.
 - ② Remove the A to C port pipes and drain pipes.
 - ③ Remove the Socket button head cap screw [23] (3 places), and then remove the ring [9].
 - ④ Remove sticky material while spraying lubricant on the gap between the inner diameter of the detectable plate [8] and the outer diameter of the rotary valve [4].
 - ⑤ After connecting the hydraulic port, repeat the push-pull operation of the cylinder several times to confirm that there is no problem.

Assemble in the reverse order of disassembly.

Tighten the Socket button head cap screw with the specified tightening torque.

(M6: 8.6 N·m)

NOTICE

- If mist adheres to the cylinder, improve the environment so that it does not adhere. If there is a lot of adhesion, the sliding resistance of the detectable plate will increase, and the detectable plate may be damaged.
- If there is a lot of mist adhering and disassembly and cleaning is required, please contact us.

7-2. Maintenance and inspection of hydraulic unit

- Clean the suction strainer every 2 to 3 months.
- Replace the hydraulic oil about once every six months.

7-3. List of seals to use (Refer to Fig. 3-5)

·HA type (M09 size is RA)

Table 7

No.	Part name	M0915RA	M1120HA21D	M1221HA21D	M1330HA21D	Quantity
24	O-ring	JIS B2401 P7	JIS B2401 P7	JIS B2401 P7	JIS B2401 P7	3
25	O-ring	JIS B2401 P12	JIS B2401 P12	JIS B2401 P12	JIS B2401 P12	3
26	O-ring	JIS B2401 P16	JIS B2401 P16	JIS B2401 P16	JIS B2401 P16	2
27	O-ring	JIS B2401 P30	JIS B2401 P30	JIS B2401 P32	JIS B2401 P36	1
28	O-ring	JIS B2401 G90	JIS B2401 G105	JIS B2401 G115	JIS B2401 G125	2 (M0915RA:1)
29	O-ring	JIS B2401 G105	-	-	-	1
30	O-ring	-	NOK S22	NOK S22	NOK S26	1
31	O-ring	NOK S34	NOK S34	NOK S34	NOK S34	1
32	O-ring	NOK S42	NOK S42	NOK S42	NOK S42	1
33	Oil seal	S33 50 7	S33 50 7	S33 50 7	S33 50 7	1
34	Teflon seal	526-P15-1204	526-P15-1204	526-P15-1204	526-P15-1204	2

·HB type

Table 8

No.	Part name	M1120HB21N	M1221HB21N	M1330HB21N	Quantity
24	O-ring	JIS B2401 P7	JIS B2401 P7	JIS B2401 P7	3
25	O-ring	JIS B2401 P12	JIS B2401 P12	JIS B2401 P12	3
26	O-ring	JIS B2401 P16	JIS B2401 P16	JIS B2401 P16	2
27	O-ring	JIS B2401 P30	JIS B2401 P32	JIS B2401 P36	1
28	O-ring	JIS B2401 G105	JIS B2401 G115	JIS B2401 G125	2
29	O-ring	NOK S22	NOK S22	NOK S26	1
30	O-ring	NOK S42	NOK S42	NOK S42	1
31	O-ring	NOK S45	NOK S45	NOK S45	1
32	Oil seal	S33 50 7	S33 50 7	S33 50 7	1
33	Teflon seal	AR400-P15-GC	AR400-P15-GC	AR400-P15-GC	1
34	Mechanical seal	EH700-15	EH700-15	EH700-15	1

·HC type

Table 9

No.	Part name	M1120HC21D	M1221HC21D	M1330HC21D	Quantity
23	O-ring	JIS B2401 P7	JIS B2401 P7	JIS B2401 P7	3
24	O-ring	JIS B2401 P12	JIS B2401 P12	JIS B2401 P12	2
25	O-ring	JIS B2401 P16	JIS B2401 P16	JIS B2401 P16	2
26	O-ring	JIS B2401 P30	JIS B2401 P32	JIS B2401 P36	1
27	O-ring	JIS B2401 G105	JIS B2401 G115	JIS B2401 G125	2
28	O-ring	NOK S42	NOK S42	NOK S42	1
29	Oil seal	S33 50 7	S33 50 7	S33 50 7	1

7-4. Special instructions

·HA type (M09 size is RA)

- Do not use coolant. Failure to follow this instruction results in breakdown.
- For the air piping, use a 3-point unit, and be sure to use oil mist.
- Do not operate the cylinder without air.
- The air pressure shall be 1.0MPa(10.2kgf/cm²) or less.
- Normally, the Teflon seal withstands 5,000 hours of operation. (However, it varies depending on the lubrication and the working pressure.) Therefore, it needs to be replaced when the following phenomena are observed.

If the volume of oil mist increases on the air circuit side, contamination of hydraulic oil may be because of wear in or damage to the Teflon seal.

To check wear, follow the procedure below. (See 1-4 HA type (M09 size is RA) parts list on pages 7-8 and 7-3 HA type (M09 size is RA) List of seals to use on pages 28.)

When removing the parts, place a match mark(s) on each part for reassembly.

(1) Remove the socket head cap screw [19](4 pieces) to remove the sleeve cover [7] and the shim ring [12].

(2) Check that the rear end of the rotary valve [4] does not get wet with oil.

Note) If it gets wet with oil, replace the Teflon seal [34] because it is worn or damaged.

(3) Check the Teflon seal [34] in the center of the sleeve cover [7] for wear. If it becomes deformed, worn on one side, etc., replace it.

To facilitate assembly at the joint and the seal part, or prevent flaws in assembling the seal, apply a sufficient amount of oil (equivalent to turbine oil #90) or of grease (general grease: Class 1) to follow the disassembly procedure in the reverse order with due care so as not to damage the bearing, the o-ring, and the Teflon seal.

Tighten the socket head cap screw with the specified tightening torque (M6:13N·m).

·HB type

- Before rotation, supply about 10cc of oil (equivalent to turbine oil #90) from the E port on the top of the sleeve cover. Failure to follow this instruction may result in damage to the mechanical seal.
- Do not use air. Failure to follow this instruction results in breakdown.
- Be sure to keep coolant running during rotation.
- Be sure to install piping to the coolant drain port (C-Dr port). Use a transparent vinyl hose, and return it to the coolant level in the coolant tank. Although coolant is not discharged from the coolant drain port in a normal state, it leaks from this port if the mechanical seal is worn or damaged. For this reason, use a transparent hose for easy checking.
- Normally, the mechanical seal withstands 8,000 hours or more of operation. However,

replace the mechanical seal if 10cc/h or more of coolant leaks from the drain port (C-Dr port) because of damage to the seal surface caused by foreign matter such as chips. Failure to do so results in damage to the mechanical seal.

- Normally, the Teflon seal withstands about 5,000 hours of operation. (However, it varies depending on the lubrication and the working pressure.) If hydraulic oil leaks from the drain port (C-Dr port), replace the Teflon seal.

To check the mechanical seal and the Teflon seal for wear, follow the procedure below. (See 1-4 HB type parts list on pages 9-10 and table 8 List of seals to use on page 28 and the following detailed drawing of the parts of the mechanical seal (Fig. 9) to be checked.)

When removing the parts, place a match mark(s) on each part for reassembly.

- (1) Remove the socket head cap screw [20] (4 pieces) to remove the cover [13].
- (2) Remove the setscrew (2 pieces) put in the mechanical seal [34] to disassemble the mechanical seal [34].

Note) If any abnormalities such as damage to the mechanical seal, flaws in the seal surface, deformation, etc. are found, replace the mechanical seal.

- (3) Remove the socket head cap screw [19] (4 pieces) to remove the sleeve cover [7].
- (4) Check the Teflon seal [33] in the center of the sleeve cover [7] for wear. If any abnormalities such as deformation, wear on one side, etc. are found, replace the Teflon seal.

To facilitate assembly at the joint and the seal part, or prevent flaws in assembling the seal, apply a sufficient amount of oil (equivalent to turbine oil #90) or of grease (general grease: Class 1) to follow the disassembly procedure in the reverse order with due care so as not to damage the bearing, the o-ring, and the Teflon seal.

Tighten the socket head cap screw with the specified tightening torque (M6: 13N·m).

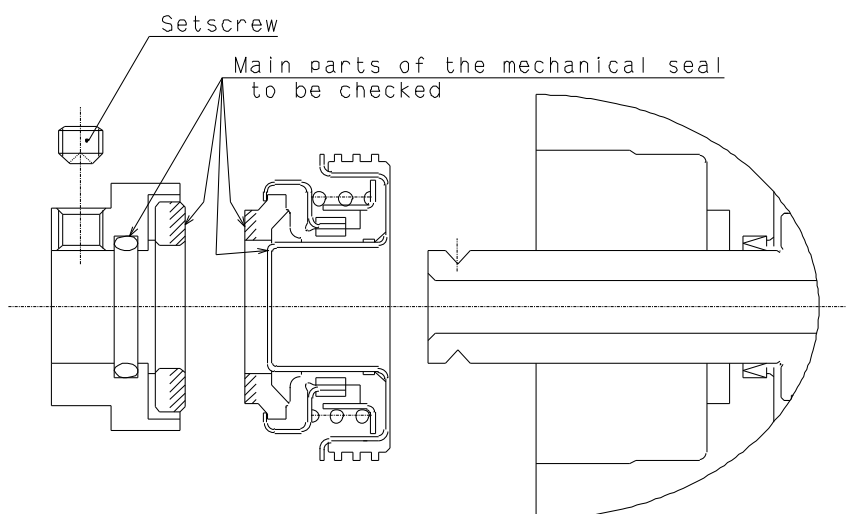

Fig.9 Detail of mechanical seal inspection part

8. Malfunction and Countermeasures

8-1. In the case of malfunction

Check the points specified below again and take measures.

Table 10

Defective	Measures
Piston Operation Inability	Check that the hydraulic pressure is operating by the motion of the flexible hose, etc.
	Check that there are no mistakes in piping.
	Try operations when operation inability specified in the items of the trial operation.
Cylinder Thrust Force Insufficiency	Check that the pressure is as specified at the cylinder pipe inlet by attaching a pressure gauge near the inlet of the cylinder.
	Wearing of the O-ring inside is possible when the flow rate of the returning side pipe or the drain is more than usual.
Temperature Rise	Check that the viscosity of the hydraulic oil is as designated.
	Replenish the hydraulic oil inside the tank if it is low.
	When the room temperature is high and the radiation effect of the tank is bad, control the oil temperature using a cooler or a fan, etc.
Pump noise	Do not suck air.
	Replenish the hydraulic oil inside the tank if it is low.
	If a large amount of dirt is deposited inside the tank, or when the hydraulic oil is deteriorated, the pump may be worn out abnormally, and it will be necessary to repair the pump.
Oil leakage from oil seal	Provide a stream slope, without air pockets, and no backpressure must be applied.
	Return the drainage onto the surface of the oil of the hydraulic unit.
	Check that the air breather of the hydraulic unit is not clogged.

**WARNING**

- If the chuck failed due to a seizure or breakage, remove the chuck from the machine, following the disassembly steps in the chuck instruction manual, and then remove the cylinder by the reverse steps of "9. Attachment" after page 33. When the jaws and covers cannot be removed due to a blockage of workpiece, do not disassemble forcibly but please contact us or our agent.
- If these countermeasures do not correct the problem or improve the situation, immediately stop using the machine. Continuous use of a broken product or a defective product may cause a serious accident by the cylinder or the work flying out.
- Only experienced and trained personnel should do repairs and fix malfunctions. Repair of a malfunction by a person who has never received instruction from an experienced person, the distributor or our company may cause a serious accident.

8-2. Where to contact in the case of malfunction

In the case of malfunction, contact the distributor where you purchased the product or our branch office listed on the back cover.

For Machine Tool Manufacturers

Following pages are described for machine tool manufacturers (personnel who attach a cylinder to a machine). Please read following instruction carefully when you attach or detach a cylinder to machine, and please sufficiently understand and follow the instructions for safe operation.

9. Attachment

9-1. Outline drawing of attachment

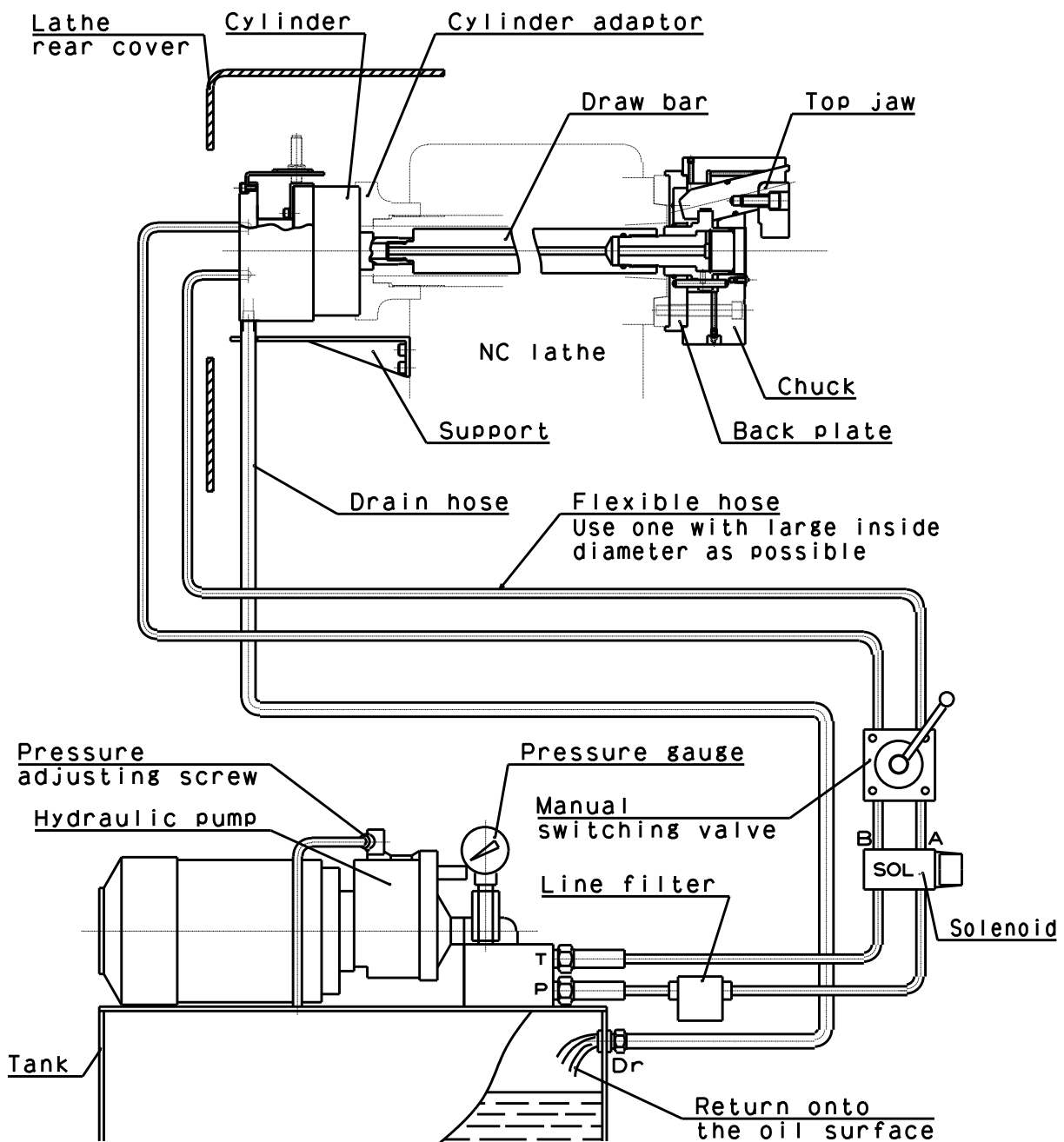

Fig. 10

- Attach the manual switching valve at a position where it is easy to operate for the attaching equipment.
- Install the hydraulic unit at a position where the drain hose is not kinked and the needle of the pressure gauge is easily read.
- Use a pipe inside diameter as large as possible.

DANGER

- **When other actuators are operated by the same hydraulic pressure source as the cylinder for chuck, be sure that a pressure drop of the cylinder does not occur during use. A hydraulic pressure drop leads to a drop in the gripping force which could allow the work to fly out.**
- **The drain hose will ensure no back pressure.**
- **The end of the hose is physically above the oil level. (Refer to Fig.10)**
- **If the hydraulic oil stagnates inside the cylinder, oil leakage occurs, which may cause a fire.**

WARNING

- **Install after removing the dust inside the pipe completely.**
- **Add a filter to the pressure supply line(P). If foreign matters gets inside the cylinder, this is dangerous since the rotation valve of the cylinder will seize, the hose will tear off, and the cylinder will rotate. This is also dangerous as the work will fly out.**
- **Always use a flexible hose for the hydraulic piping to the cylinder, and the bending force or tensile force of the pipe must not be applied to the cylinder. Use a pipe inside diameter as large as possible and keep the piping length as short as possible.**

NOTICE

- Provide an air passage behind the cylinder or a window about the size of the sleeve cover on the lathe rear cover for the hot air generated from the cylinder to escape to the outside.

9-2. Production and attachment of cylinder adapter

NOTICE

- Attach with the surface run-out of the cylinder adapter and the run-out of the spigot joint at 0.005 mm or less, and the face is not convex upward. (Fig. 12) Large run-out causes vibration and shortens the life of the cylinder significantly.

- Bring the cylinder as close to the lathe spindle support as possible. The attaching method of the cylinder adapter and the measuring method of run-out are illustrated in the drawings below. (Fig. 11, Table 11)
- Never fail to provide a setscrew to prevent loosening of the cylinder adapter. (Fig. 12)

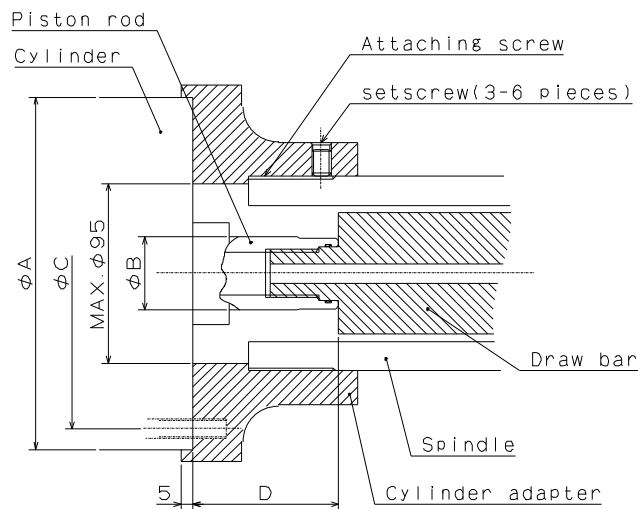

Cylinder adapter attaching part

Fig. 11

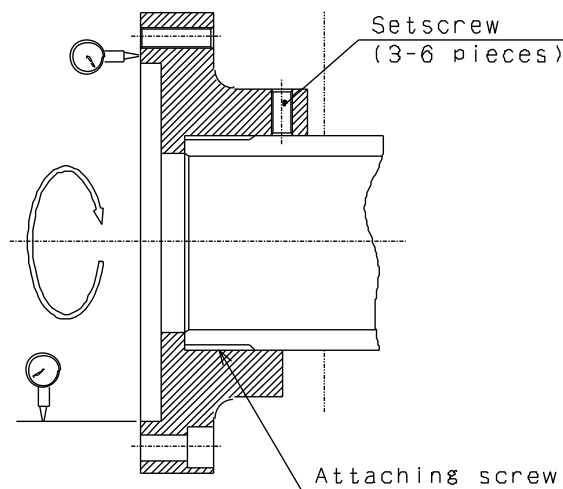

Run-out measurement of the cylinder adapter

Fig. 12

Table 11

(Unit mm)

Type	$\phi A(F7)$	ϕB	ϕC	D (MAX)	Socket head cap screw
M0915RA	145	30	130	101	6-M8
M1120HA21D M1120HB21N M1120HC21D	145	30	128	60	6-M8
M1221HA21D M1221HB21N M1221HC21D	168	32	145	60	6-M10
M1330HA21D M1330HB21N M1330HC21D	168	36	150	60	6-M10

9-3. Production and attachment of draw bar

- Determine the length of the draw bar as shown below.
- When screwing the draw bar into the piston, screw in a state that the piston comes inside.



- Sufficiently degrease and apply adhesive on the thread part of the piston and the thread part of the draw bar, and then screw in and tighten.
- If the screw is loose, the jaw stroke of chuck will shorten, which could allow the work to fly out.

• M1120HA/HB/HC、M1221HA/HB/HC、M1330HA/HB/HC

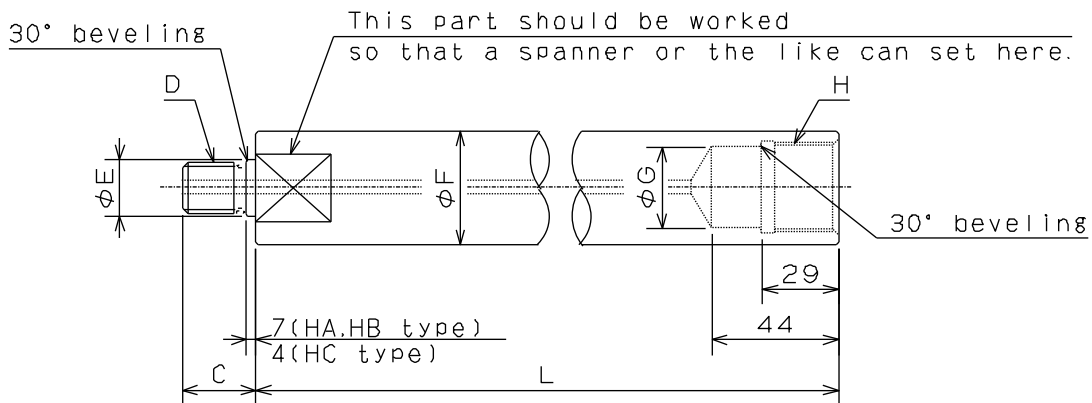

Fig.13

HA (M09 size is RA) and HB type: Prepare the appearance and the 30-degree beveling which do not damage an o-ring.

• M0915RA

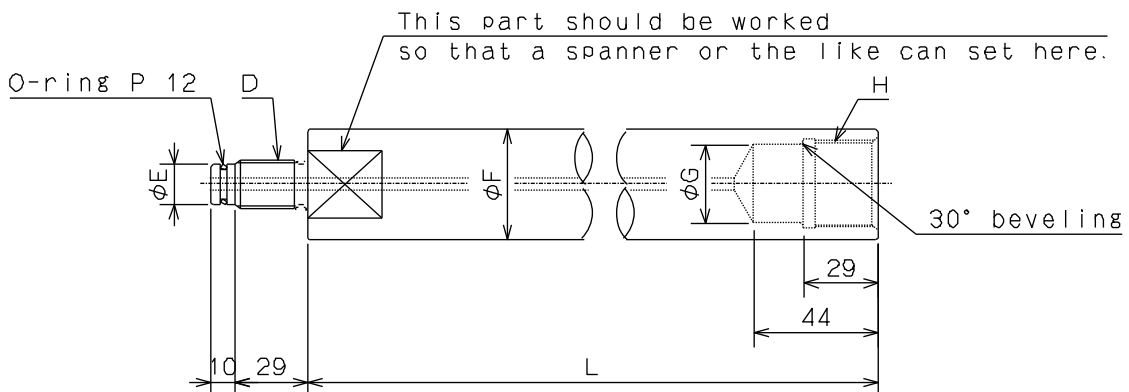

Fig.14

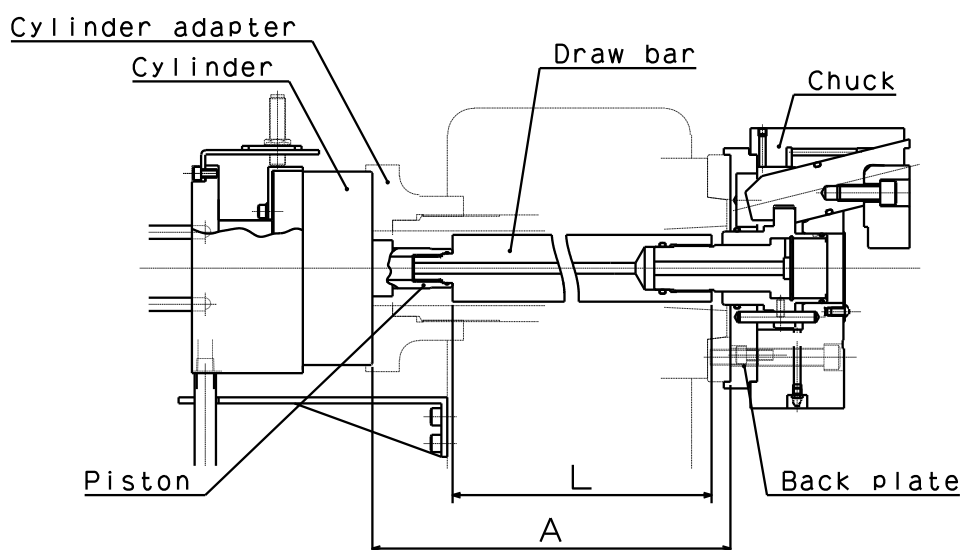

Fig.15

Table 12

Type	Chuck	C	D	E	F	G	H	L
M0915RA	PU206 ※1	--	M20	16	35	26	M28 × 1.5	A-112
M1120HA21D M1120HB21N M1120HC21D	PU208	29	M20	22	45	32	M35 × 1.5	A-71
M1221HA21D M1221HB21N M1221HC21D	PU210	29	M20	22	50	35	M38 × 1.5	A-72
M1330HA21D M1330HB21N M1330HC21D	PU212	34	M24	26	55	42	M45 × 1.5	A-72

※1: In this combination, max speed is restricted to 6000min⁻¹.

The dimension L in Fig.13,14 is determined from the distance A between the cylinder adapter and the back plate.

Example) In the case of PU208, M1120HA21D, the cylinder adapter and back plate distance A = 800,

The total length of the draw bar is to be $L = A - 71 = 800 - 71 = 729$.

At the time of the screw process of the dimension D, the precision is to be JIS 6H and 6h, 6g matching the screw of the piston of the cylinder. Pay attention so that the thread parts on both ends and the outer periphery do not swing or become unbalanced.



- **Provide sufficient strength for the draw bar.** If the draw bar is broken due to insufficiency of the strength, the gripping force will be lost instantly, which is dangerous as the work will fly out.
 - Material with the tensile strength 580MPa (58kgf/mm²) or more must be used for the draw bar.
 - The personnel who designed draw bar must judge whether the strength of the draw bar is sufficient for the usage conditions.
 - The dimensions and materials specified in this manual do not guarantee that the draw bar will not break under every usage condition.
- **If the screw-in depth of the draw bar to the draw nut is insufficient,** the screw will break and the gripping force will be lost instantly, which is dangerous as the work will fly out.
- **If the draw bar is unbalanced,** vibration occurs, the screw is broken and the gripping force will be lost instantly, which is dangerous as the work will fly out.
- **If the engagement of the screw of the draw bar is loose,** vibration may occur resulting in breakage of the screw. If the screw breaks, the gripping force will be lost instantly, which is dangerous as the work will fly out.

9-4. Attachment of cylinder

- When removing/installing the cylinder, use a lifting belt and perform as follows. (Fig.16)
 - To lift up the cylinder, engage a lifting belt with the draw-bar and lift up the cylinder while supporting it.
 - Insert the draw-bar into the spindle.
 - When a lifting belt comes close to the spindle, shift the lifting belt toward the cylinder.
 - When the draw-pipe has entered the spindle sufficiently, re-engage a lifting belt with the cylinder body and fit the cylinder closely to the spindle and then install the cylinder with the cylinder mounting bolts.

Detach in the reverse procedures of attachment.

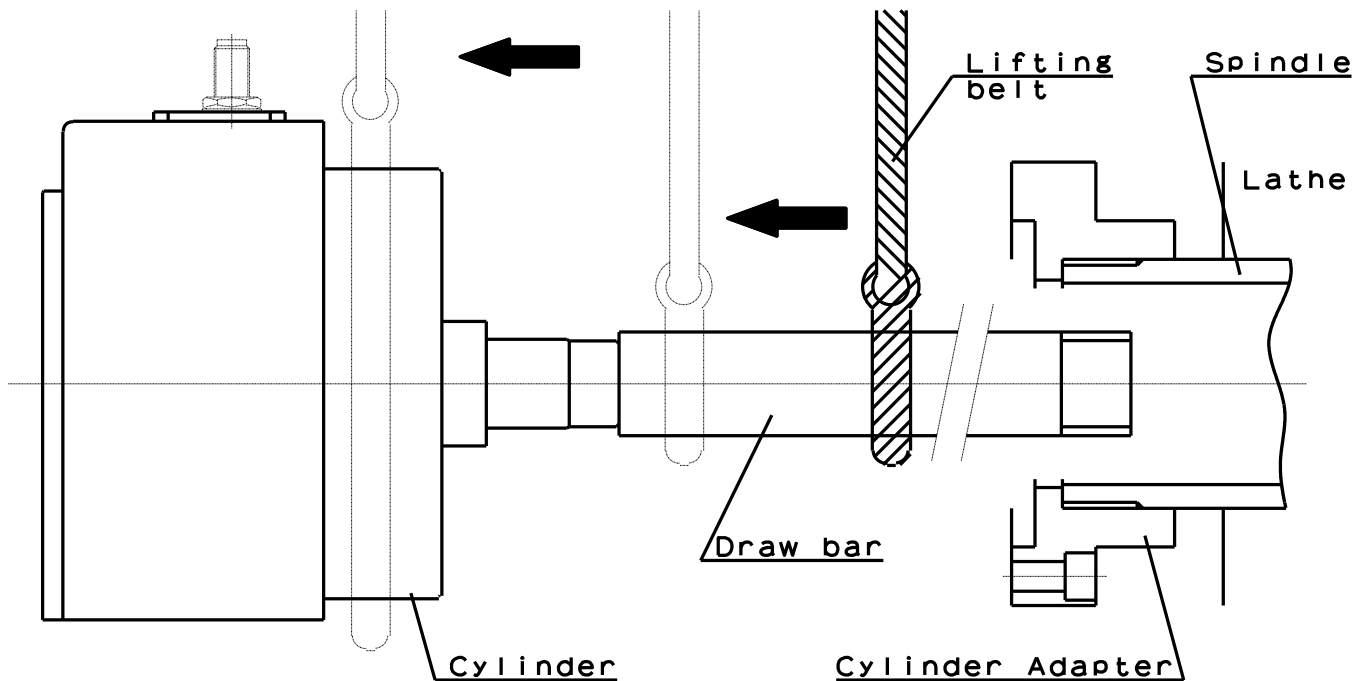

Fig.16

CAUTION

- Use a lifting belt when attaching and detaching the cylinder to and from the machine, as there is a danger of injury or damage if the cylinder drops.
- Use the belt in the center of gravity not to lose the balance, and lift the draw pipe slowly. If balance is bad, the belt slips, and the cylinder drops, and there is the injury danger such as blows.

NOTICE

- To prevent the sleeve cover of the cylinder from rotating, provide a support by utilizing the screw of sleeve cover.
- After attaching the support to the lathe, provide clearance between the screw of the sleeve cover and the support so that force is not applied to the sleeve cover.

- Arrange the drain hose to come back to the above of oil tank surface of the hydraulic unit.(Fig.10) If the drain hose is connected to T-port such as valve block, etc., the oil seal of cylinder will damage because back pressure is applied to the hose.
- As for the run-out when attaching the cylinder, attach the cylinder while keeping the vertical run-out of the sleeve cover rear end and the cylinder periphery at the standard value specified in the Fig.18 or lower when rotation stop of the sleeve cover is applied and the spindle is rotated.

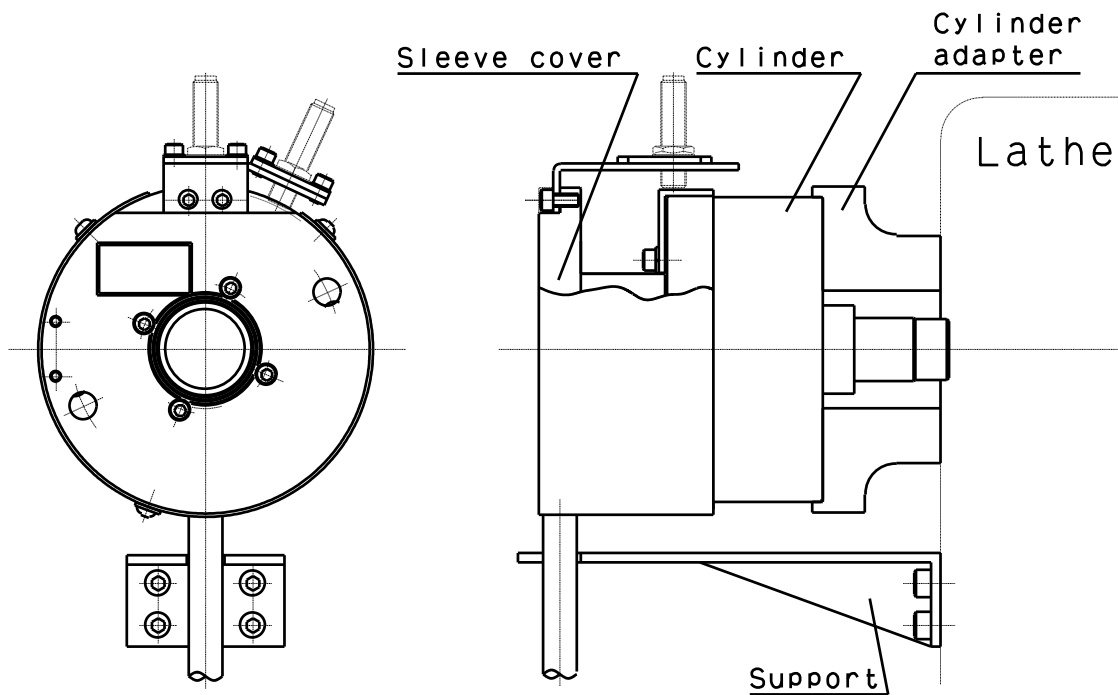

Fig. 17

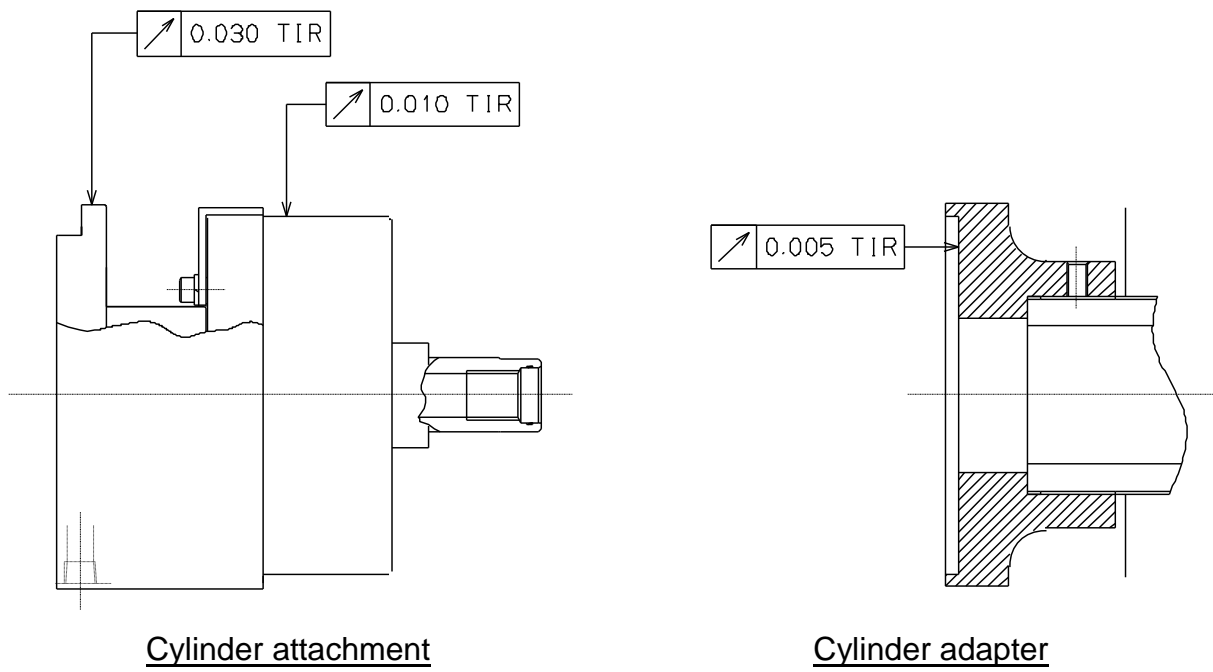

Fig.18

To obtain the above specified value of run-out, make the surface run-out of the cylinder adapter as small as possible. (0.005 mm TIR or less)

9-5. Tightening torque of the cylinder attaching bolt

- In the case of attaching the cylinder to the cylinder adapter, follow the downward below for the tightening torque of the attaching bolt.

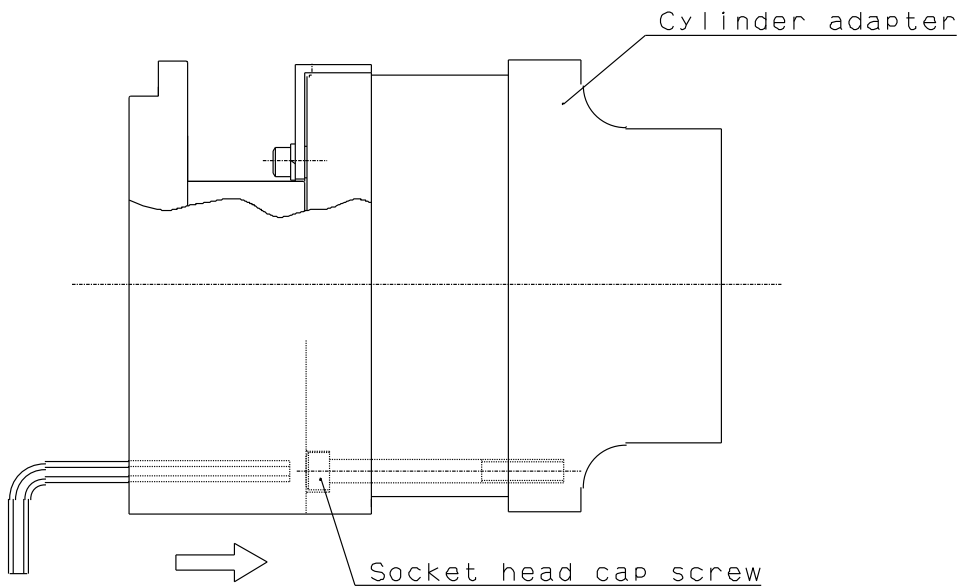

Fig. 19

! DANGER

- Always tighten the bolts at the specified torque. If the torque is insufficient or excessive, the bolt will break, which is dangerous as the cylinder or work will fly out.
- Use the bolts attached to the chuck, and do not use other bolts. However, if you must use other bolts not provided by Kitagawa, use bolts that have at least a strength classification of 12.9 (10.9 for M22 or more) and be sure they are long enough.

Table 13

Bolt size	Tightening torque
M8	33 N·m
M10	73 N·m

10. About Hydraulic Circuit Design

- Consider the hydraulic circuit design so that the operation is easy and no mistakes in operation occur.
Attempt failsafe for the circuit so as not to cause any accidents even in the case of blackout. (Fig. 20)
- It is incorporated with a lock mechanism (lock valve) to maintain the specified gripping force even if the supplied pressure abnormally drops due to blackout or malfunction of the pressure resource while processing a work, however, it does not function unless the following warnings are observed.



- Additionally, the solenoid valve is to be in a circuit to retain the gripping port position when no electric current is carried.
The switching of the cylinder is to be 4 port 2 position with electromagnetic valve, and design the hydraulic circuit which grips the work in the state that the solenoid valve is degaussed.
If the circuit is designed in the opposite way, if there is a blackout, the work could be released and fly out.
- Provide a valve to switch over the inside and outside diameter gripping to prevent an operation mistake when changing the gripping.
Additionally, when a solenoid valve is used as this switching valve, use a 4 port 2 position valve with a position stopper that can retain the indicator circuit at the time of blackout.

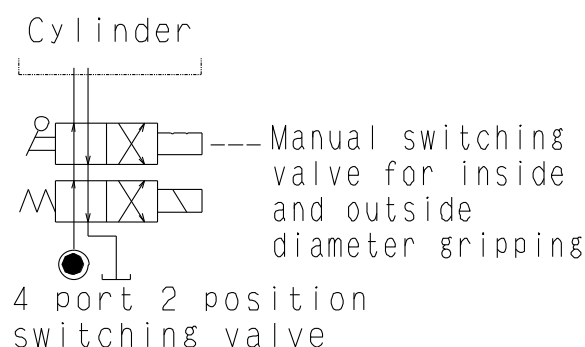

Fig. 20

- It is incorporated with a mechanism to stop damage when the hydraulic oil filled inside the cylinder has increased its pressure due to the volume change (relief valve). Pay attention to the points specified below for functional maintenance of lock valve and relief valve.

 **DANGER**

- Assemble piping after completely removing the dust inside the pipe for functional maintenance of lock valve and relief valve.
- If the function of the lock valve lowers, this is dangerous as the work will fly out when the hydraulic pressure suddenly lowers due to blackout or malfunction of the hydraulic pump, etc.
- If the function of the relief valve lowers, the volume of the filled hydraulic oil changes causing an increase in pressure, which is dangerous resulting in malfunction.

 **WARNING**

- To avoid serious injury from flying work, use the throttle valve to keep the surge pressure low. Operation failure and cylinder breakage may occur if a reducing valve used for the hydraulic pressure setting fails to respond to pressure adjustment and results in excessive surge pressure.

Remark) What is a “surge pressure”?

Pressure produced by a change in velocity of the moving stream that result from activating a hydraulic pump, operation of a solenoid valve.

NOTICE

- Select the operation equipment that matches the pipe diameter of the cylinder. The smaller the diameter is, the larger the pipe resistance becomes and the lower the acting speed is.

<Installation>

The hydraulic pressure supply ports are port A (cylinder pushing side) and port B (cylinder pulling side) in Fig.21-23.

For the size of each port, see Table 14.

Table 14

Type	M0915	M1120	M1221	M1330
A port	Rc1/4			
B port	Rc1/4			
Ar port (M-HC)	Rc1/8			
C port (M-HB)	Rc1/4			
Dr port	Rc1/4			

表 15

Port size	Tightening torque
Rc1/8	5N·m
Rc1/4	10N·m



- **Tighten plumbing and plug at the specified torque. If the torque is insufficient or excessive, the cylinder will break and cause oil leakage which could result in a fire. It is dangerous because leakage cause the hydraulic pressure drop and work flying out.**

11. Other information

11-1. About standards and orders

This product is based on the following standards or orders.

- Machinery directive:2006/42/EC Annex I
- EN ISO 12100:2010
- EN1550:1997+A1:2008

11-2. Information about markings of product

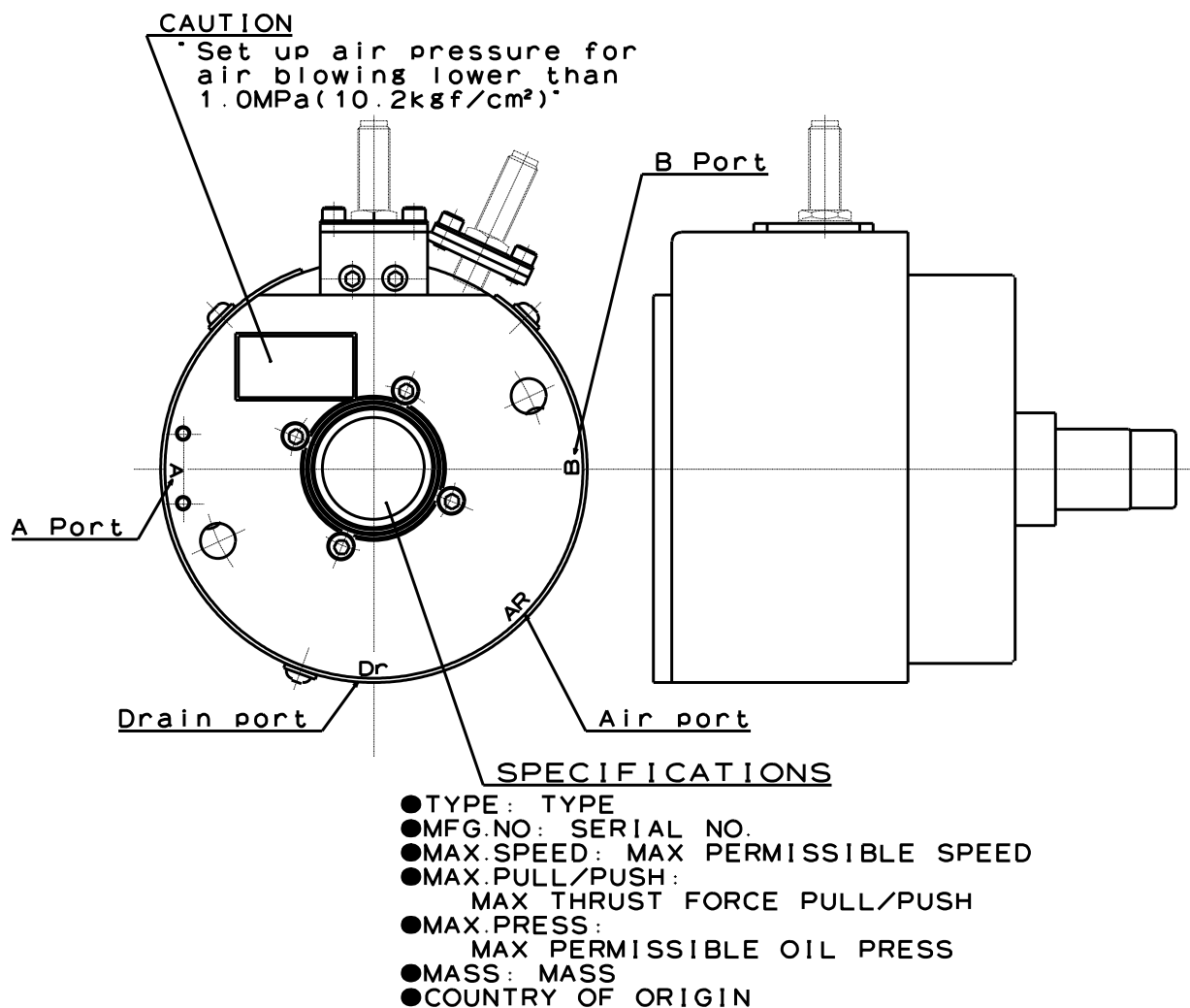

Fig.21 M-HA type (M09 size is RA)

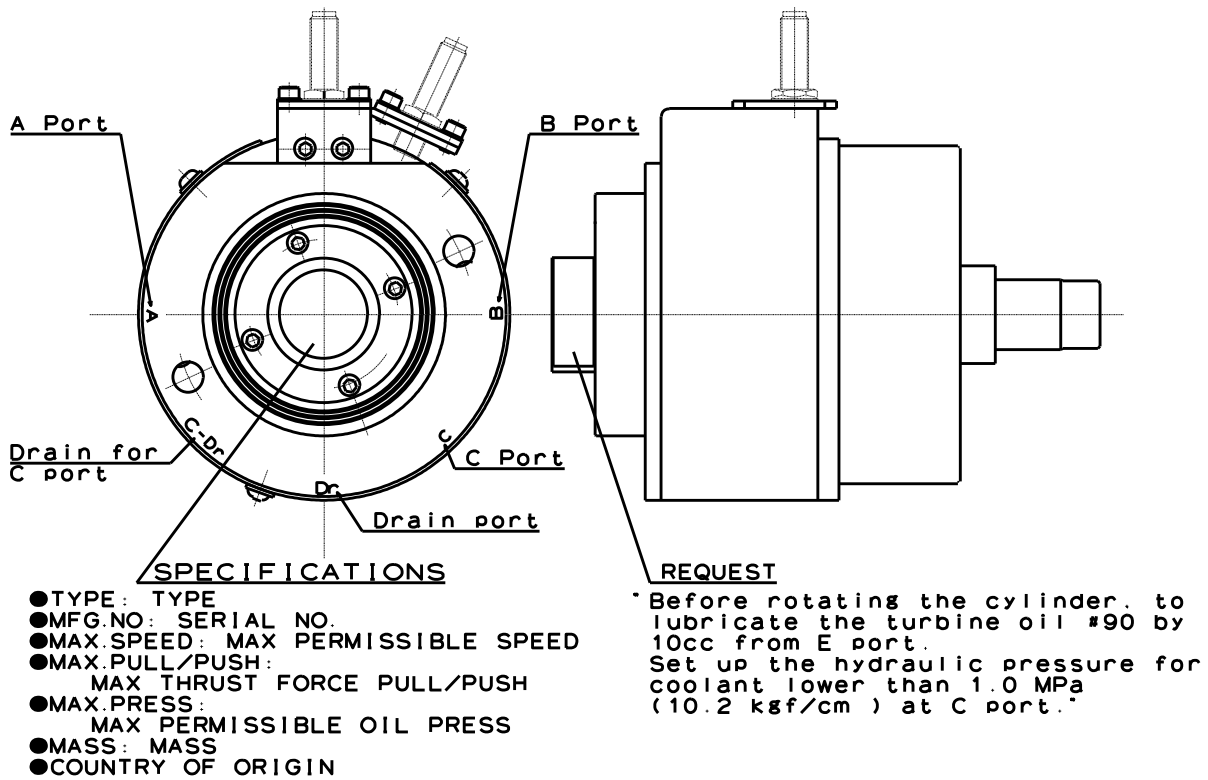

Fig.22 M-HB type

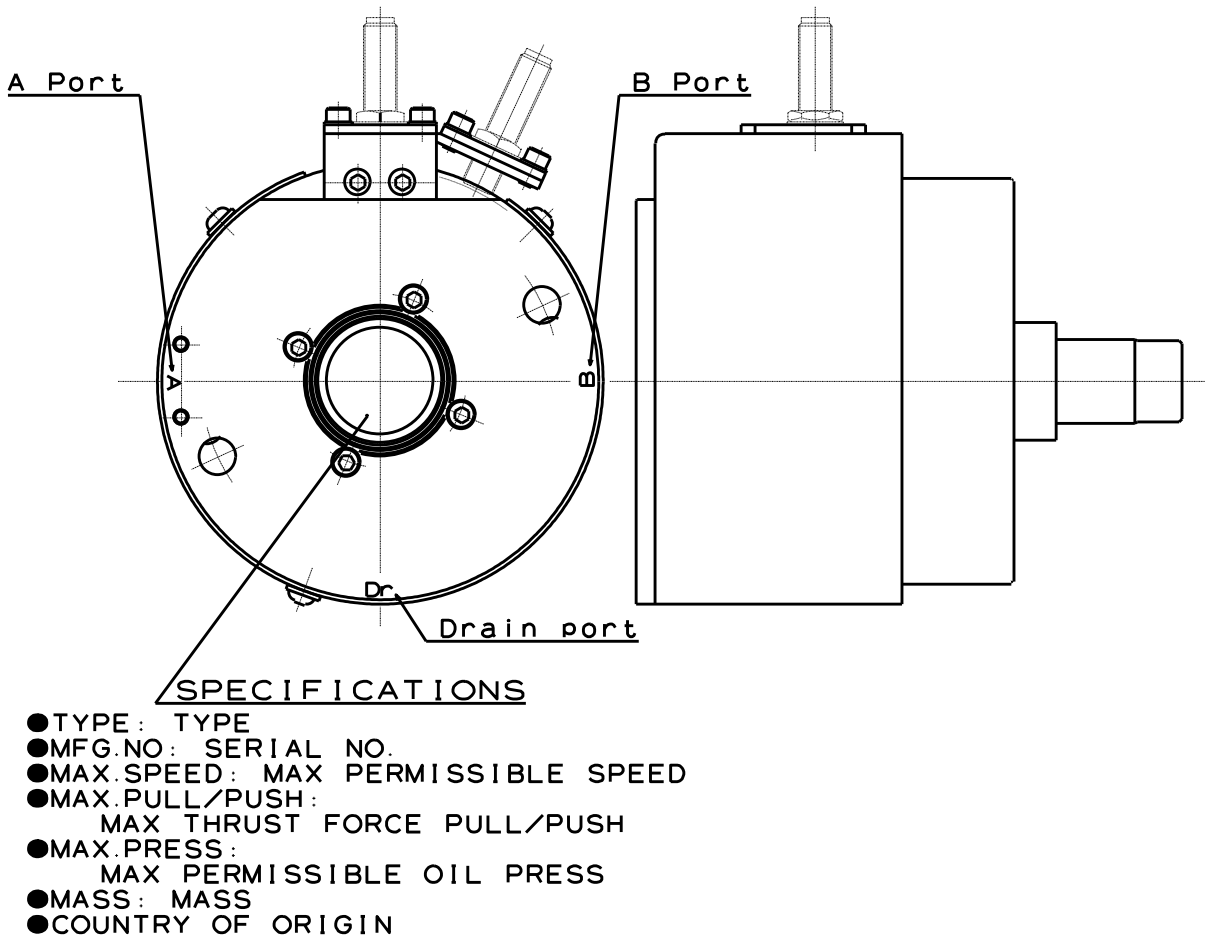

Fig.23 M-HC type

11-3.About disposal

Ultimate disposal of this product should be handled according to all national laws and regulations.

DECLARATION OF INCORPORATION

of partly completed machinery

Copy of original

We hereby declare that the following our product conform with the essential health and safety requirements of the EC Machinery Directive so that the product is to be incorporated into end-machinery. The product must not be put into service until end-machinery has been declared in conformity with the provisions of the EC Machinery Directive 2006/42/EC Annex II part 1.A.

We also declare that the specific technical documentation for this partly completed machinery was drawn up according to the EC Machinery Directive 2006/42/EC Annex VII part B.

Product	: Cylinder
Model	: M series (Models M0915RA, M1120HA, M1120HB, M1120HC, M1221HA, M1221HB, M1221HC, M1221HD, M1330HA, M1330HB, M1330HC)
Serial number	: See original declaration
Manufacturer	: Kitagawa Corporation 77-1, Motomachi, Fuchu-shi, Hiroshima 726-8610, Japan
Authorized compiler in the community	: Peter Soetebier / Prokurist Kitagawa Europe GmbH Borsigstr.3 D-40880 Ratingen, GERMANY

The essential health and safety requirements in accordance with the EC Machinery Directive 2006/42/EC Annex I were applied and fulfilled:
1.1.2, 1.1.3, 1.1.5, 1.1.6, 1.2.6, 1.3.1, 1.3.2, 1.3.4, 1.5.3, 1.5.4, 1.5.8, 1.5.9, 1.5.13,
1.6.1, 1.7.1, 1.7.2, 1.7.3, 1.7.4, 1.7.4.1, 1.7.4.2

The following harmonized standards were applied:
EN ISO 12100:2010, EN 1550:1997+A1: 2008

Signature : See original declaration

Place / Date : See original declaration

Name / Title : Tomonari Hiromoto / Manager, Technical section 1
Technical department
Kitagawa Global hand Company

Being the responsible person appointed and employed the manufacturer.

UK DECLARATION OF INCORPORATION

of partly completed machinery

Copy of original

We hereby declare that the following our product conform with the essential health and safety requirements of the Supply of Machinery (Safety) Regulations 2008 so that the product is to be incorporated into end-machinery. The product must not be put into service until end-machinery has been declared in conformity with the provisions of the Supply of Machinery (Safety) Regulations 2008 Annex II part 1.A.

We also declare that the specific technical documentation for this partly completed machinery was drawn up according to the Supply of Machinery (Safety) Regulations 2008 Annex VII part B.

Product	: Cylinder
Model	: M series (Models M0915RA, M1120HA, M1120HB, M1120HC, M1221HA, M1221HB, M1221HC, M1221HD, M1330HA, M1330HB, M1330HC)
Serial number	: See original declaration
Manufacturer	: Kitagawa Corporation 77-1, Motomachi, Fuchu-shi, Hiroshima 726-8610, Japan
Authorized complier in the community	: Mark Jones / Financial Director UNIT 1 THE HEADLANS, DOWNTON, SALISBURY, WILTSHIRE, SP5 3JJ, UNITED KINGDOM

The essential health and safety requirements in accordance with the Supply of Machinery (Safety) Regulations 2008 Annex I were applied and fulfilled:
1.1.2, 1.1.3, 1.1.5, 1.1.6, 1.3.1, 1.3.2, 1.3.4, 1.5.4, 1.5.8, 1.5.9, 1.5.13, 1.6.1, 1.7.1,
1.7.2, 1.7.3, 1.7.4, 1.7.4.1, 1.7.4.2

The following harmonized standards were applied:
EN ISO 12100:2010, EN 1550:1997+A1: 2008

Signature : See original declaration

Place / Date : See original declaration

Name / Title : Tamio Nishimiya / Manager, Technical section 3
Technical department
Kitagawa Global hand Company

Being the responsible person appointed and employed the manufacturer.

Kitagawa Corporation Kitagawa Global hand Company
 77-1, Motomachi, Fuchu-shi, Hiroshima, 726-8610, Japan

Tel. +81-847-40-0561 Fax. +81-847-45-8911

■ JAPAN DOMESTIC

Tokyo office	1-405-1, Kita-ku, Yosino-cho, Saitama-shi, Saitama, 331-9634, JAPAN Tel. +81-48-667-3469 Fax. +81-48-663-4678
Sendai office	4-15-13, Yamatomachi, Wakabayashi-ku, Sendai-shi, Miyagi, 984-0042, Japan Tel. +81-22-232-6732 Fax. +81-22-232-6739
Nagoya office	2-62, Kamitakabata, Nakagawa-ku, Nagoya-shi, Aichi, 454-0873, Japan Tel. +81-52-363-0371 Fax. +81-52-362-0690
Osaka office	3-2-9, Kitakagaya, Suminoe-ku, Osaka-shi, Osaka, 559-0011, Japan Tel. +81-6-6685-9065 Fax. +81-6-6684-2025
Hiroshima office	77-1, Motomachi, Fuchu-shi, Hiroshima, 726-8610, Japan Tel. +81-847-40-0541 Fax. +81-847-46-1721
Kyushu office	7-6-39, Itazuke, Hakata-ku, Fukuoka-shi, Fukuoka, 812-0888, Japan Tel. +81-92-501-2102 Fax. +81-92-501-2103
Overseas office	77-1, Motomachi, Fuchu-shi, Hiroshima, 726-8610, Japan Tel. +81-847-40-0526 Fax. +81-847-45-8911

■ OVERSEAS

America Contact	KITAGAWA-NORTHTECH INC. https://www.kitagawa-usa.com 301 E. Commerce Dr, Schaumburg, IL. 60173 USA Tel. +1 847-310-8787 Fax. +1 847-310-9484
	KITAGAWA MEXICO S.A. DE C.V Circuito Progreso No. 102, Parque Industrial Logistica Automotriz, Aguascalientes, Ags., C.P.20340 Tel. +52 449-917-8825 Fax. +52 449-971-1966
Europe Contact	KITAGAWA EUROPE LTD. https://www.kitagawa.global/en Unit 1 The Headlands, Downton, Salisbury, Wiltshire SP5 3JJ, United Kingdom Tel. +44 1725-514000 Fax. +44 1725-514001
	KITAGAWA EUROPE GmbH https://www.kitagawa.global/de Borsigstrasse 3, 40880, Ratingen Germany Tel. +49 2102-123-78-00 Fax. +49 2102-123-78-69
	KITAGAWA EUROPE GmbH Poland Office https://www.kitagawa.global/pl 44-240 Zory, ul. Niepodleglosci 3 Poland Tel. +48 607-39-8855
	KITAGAWA EUROPE GmbH Czech Office https://www.kitagawa.global/cz Purkynova 125, 612 00 Brno, Czech Republic Tel. +420 603-856-122 Fax. +420 549-273-246
	KITAGAWA EUROPE GmbH Romania Office https://www.kitagawa.global/ro Strada Heliului 15, Bucharest 1, 013991, Romania Tel. +40 727-770-329
	KITAGAWA EUROPE GmbH Hungary Office https://www.kitagawa.global/hu Dery T.u.5, H-9024 Győr, Hungary Tel. +36 30-510-3550
Asia Contact	KITAGAWA INDIA PVT LTD. https://www.kitagawa.global/in Plot No 42, 2nd Phase Jigani Industrial Area, Jigani, Bangalore – 560105, Karnataka, India Tel. +91-80-2976-5200 Fax. +91-80-2976-5205
	KITAGAWA TRADING (THAILAND) CO., LTD. https://www.smri.asia/jp/kitagawa/ 9th FL, Home Place Office Building, 283/43 Sukhumvit 55Rd. (Thonglor 13), Klongton-Nua, Wattana, Bangkok 10110, Thailand Tel. +66 2-712-7479 Fax. +66 2-712-7481
	Kitagawa Corporation(Shanghai) https://www.kitagawa.com.cn Room308 3F Building B. Far East International Plaza, No.317 Xian Xia Road, Chang Ning, Shanghai, 200051, China Tel. +86 21-6295-5772 Fax. +86 21-6295-5792
	Kitagawa Corporation(Shanghai) Guangzhou Office B07, 25/F, West Tower, Yangcheng International Trading Centre, No.122 East Tiyu Road, Tianhe District, Guangzhou, China Tel. +86 20-2885-5276
	DEAMARK LIMITED https://www.deamark.com.tw No. 6, Lane 5, Lin Sen North Road, Taipei, Taiwan Tel. +886 2-2393-1221 Fax. +886 2-2395-1231
Oceania Contact	KITAGAWA KOREA AGENT CO., LTD. http://www.kitagawa.co.kr 803 Ho, B-Dong, Woolim Lion's Valley, 371-28 Gasan-Dong, Gumcheon-Gu, Seoul, Korea Tel. +82 2-2026-2222 Fax. +82 2-2026-2113
	DIMAC TOOLING PTY. LTD. https://www.dimac.com.au 69-71 Williams Rd, Dandenong South, Victoria, 3175 Australia Tel. +61 3-9561-6155 Fax. +61 3-9561-6705